

Installation Manual: VH4 Series - 14.3 SEER2/7.5 HSPF2 Horizontal Discharge Heat Pump



**REFRIGERANT SAFETY
GROUP A2L**

 **CAUTION**

Risk of fire

This unit uses a mildly flammable (A2L) refrigerant. See [A2L refrigerant safety considerations](#) to ensure safe installation, operation, and servicing of this unit.

BHC Group Heating & Cooling, 5005 York
Drive, Norman, OK 73069

6746765-UIM-C-0526
Supersedes: 6746765-UIM-B-0226

2026-05-14

C

Contents

About the VH4 outdoor unit.....	5
Certification.....	5
GoTemp Pro app (Formerly DS Solutions app).....	5
Safety.....	6
Understanding safety symbols and instructions.....	6
Safety requirements.....	6
A2L refrigerant safety considerations.....	8
General.....	9
Room size requirements.....	9
Mechanical ventilation.....	10
Refrigerant equipment checks.....	11
Electrical devices checks.....	11
Detection of refrigerant.....	12
Decommissioning.....	12
Preparing for installation.....	13
Selecting a location for installation.....	13
Planning the refrigerant piping system.....	16
Selecting the outdoor unit model.....	17
Accessories for long pipe installation.....	20
Inspecting the unit.....	21
Transporting and handling the unit.....	21
Understanding installation and operation limitations.....	21
Meeting requirements for R-454B equipment.....	23
Sourcing additional parts.....	23
Installing the outdoor unit.....	23
Installing the outdoor unit as a replacement unit.....	23
Understanding requirements for low-ambient conditions.....	24
Installing the drain elbow and drain hose.....	25
Setting the outdoor unit on the ground or a roof.....	25
Mounting the outdoor unit on a wall.....	27
Affixing the brand label.....	28
Installing the refrigerant piping.....	28
Installing the vapor and liquid lines.....	28
Installing oil traps in the vapor line.....	30
Installing the liquid-line filter drier.....	30
Brazing the refrigerant lines and service valves.....	31

Checking for refrigerant leaks.....	33
Required procedures for A2L systems.....	33
Evacuating the refrigerant lines and indoor coil.....	34
Releasing the refrigerant into the system.....	34
Adjusting refrigerant charge.....	36
Connecting the wiring.....	36
Completing the field wiring connections.....	36
Control wiring diagrams.....	41
Low-voltage wire connections for VH4 heat pump.....	42
Performing electrical checks.....	42
Starting up the system.....	43
Adjusting system settings.....	44
Activating alternate temperature and pressure mode for all VH4 outdoor models.....	45
Activating pump down mode for all VH4 outdoor models.....	45
Activating forced defrost mode for all VH4 outdoor models.....	47
Checking outdoor unit parameters.....	47
Running a parameter query for all VH4 outdoor models.....	48
System components and operation.....	49
Refrigerant cycle.....	49
Control boards for VH412E2S11, VH418E2S11, VH424E2S11, VH430E2S11, and VH436E2S11 units.....	52
Control boards for VH442E2S11, VH448E2S11, and VH460E2S11 units.....	53
Heating and cooling operation and safety components.....	55
Sensor parameters.....	56
Troubleshooting.....	57
Checking refrigerant system components.....	57
Checking cooling and heating operation.....	58
Viewing fault codes and protection codes for all VH4 outdoor models.....	60
Normal malfunction.....	62
Outdoor unit faults and protection.....	63
Drive faults.....	69
Overload in cooling mode.....	71
Overload in heating mode.....	71
Wiring diagrams.....	73
Start-up sheet.....	75

About the VH4 outdoor unit

Read all sections of this manual. Keep this manual and the manual for the matching indoor unit for future reference.

The VH4 outdoor unit is designed to connect to a matching indoor coil with sweat connect lines. You must match the VH4 outdoor unit with a single, ducted indoor unit. The VH4 outdoor unit is not designed for application in a ductless configuration. Refer to the *Technical Guide* for permissible system configurations. Sweat connect units are factory charged with refrigerant for a nominal sized matching indoor coil and 15 ft of field-supplied lines.

Certification



Assembled at a facility with
an ISO 9001:2015-certified
Quality Management
System

GoTemp Pro app (Formerly DS Solutions app)

BHC Group Heating & Cooling believes in empowering our customers with up-to-date, unit-specific information. Download GoTemp Pro app, a powerful, comprehensive app designed for contractors on the jobsite, available now in the App Store for iOS and Google Play for Android. Use the app to scan the unique QR code on the unit rating plate for easy access to product information and resources such as nomenclature, technical guide, installation manual, wiring diagrams, parts list, product registration, warranty, and much more. Simplify your tasks, save time, and stay ahead with the most comprehensive app built for professionals.



iOS



Android

Safety

It is important to understand the safety symbols used in this manual. Read safety information carefully and follow all safety requirements to ensure correct installation.

Understanding safety symbols and instructions

 This is a safety alert symbol. When you see this symbol on labels or in manuals, be alert to the potential for personal injury.

Understand and pay particular attention to the signal words **DANGER**, **WARNING**, **CAUTION**, as well as the **NOTICE**, **Important**, and **Note** alerts.

DANGER indicates an **imminently** hazardous situation, which, if not avoided, **will result in death or serious injury**.

WARNING indicates a **potentially** hazardous situation, which, if not avoided, **could result in death or serious injury**.

CAUTION indicates a **potentially** hazardous situation, which, if not avoided **may result in minor or moderate injury**. It is also used to alert against unsafe practices and hazards involving only property damage.

NOTICE indicates information considered important, but not hazard-related, such as messages relating to property damage.

Important indicates information that is essential to complete a task or may result in damage to the device if not followed.

Note indicates something of special interest or importance. Notes can contain any type of information except safety information.

Safety requirements

You must match the outdoor unit with an indoor unit with R-454B refrigerant.

Use the specified filter drier on the liquid pipe when connecting the indoor and outdoor units.

WARNING

Incorrect installation may create a condition where the operation of the product could cause personal injury or property damage. Incorrect installation, adjustment, alteration, service, or maintenance can cause injury or property damage. Refer to this installation manual for assistance or for additional information, consult a qualified contractor, installer, or service agency.

WARNING

Electrical Shock Hazard

Disconnect and lock out power before servicing. Wait 5 min to ensure that drive capacitors are discharged before servicing. Use compressor with grounded system only. Molded electrical plug must be used for connection to compressor.

 **WARNING****Burn Hazard**

Failure to follow these warnings could result in serious personal injury or property damage. Ensure that materials and wiring do not touch high temperature areas of the compressor. Personal safety equipment must be used.

 **CAUTION**

R-454B systems operate at lower pressures than R-410A systems. Do not use R-410A service equipment or components on R-454B equipment. Service equipment must be rated for R-454B.

 **CAUTION**

This product must be installed in strict compliance with the enclosed installation instructions and any applicable local, state, and national codes including, but not limited to building, electrical, and mechanical codes.

 **CAUTION****Drive Handling**

Caution must be used when lifting and installing the drive. Failure to use caution may result in bodily injury. Personal safety equipment must be used. Failure to follow these warnings could result in personal injury or property damage.

 **CAUTION****Safety Statements**

Only qualified and authorized HVAC or refrigeration personnel are permitted to install, commission and maintain this equipment. Electrical connections must be made by qualified electrical personnel. All valid standards and codes for installing, servicing, and maintaining electrical and refrigeration equipment must be observed.

A2L refrigerant safety considerations

 **CAUTION**

You must read all of this section before installing this unit.

 **WARNING**

Do not use means to accelerate the defrosting process or to clean, other than those recommended by the manufacturer.

The appliance shall be stored in a room without continuously operating ignition sources (for example, open flames, an operating gas appliance, or an operating electric heater).

Do not pierce or burn.

Be aware that refrigerants may not contain an odor.

 **WARNING**

Any required ventilation openings must be kept clear of obstruction.

 **WARNING**

Auxiliary devices which may be a potential ignition source shall not be installed in the duct work, unless they have been approved by the appliance manufacturer or are suitable for use with the refrigerant being used.

Examples of such potential ignition sources are hot surfaces with a temperature exceeding 700 °C and electric switching devices.

 **WARNING**

Any indoor field-made refrigerant joints shall be tightness tested with no leaks detected. The test method shall have a sensitivity of 5 grams per year of refrigerant or better under a pressure of at least 25% of the maximum allowable pressure.

General

Table 1: General

Item number	Safety consideration
1	Any room with an appliance containing more than 3.91 lb in a refrigerating circuit must be constructed such that any refrigerant leak cannot stagnate in a way that would create a fire or explosion hazard.
2	Before beginning work on systems containing flammable refrigerants, safety checks are necessary to ensure that the risk of ignition is minimized. For repair to the refrigerating system, item 3 to item 7 below must be adhered to before conducting work on the system.
3	Work must be undertaken under a controlled procedure so as to minimize the risk of a flammable gas or vapor being present while the work is being performed.
4	Instruct all maintenance staff and others working in the local area on the nature of work being carried out. Avoid work in confined spaces.
5	The area must be checked with an appropriate refrigerant detector before and during work to ensure the technician is aware of potentially toxic or flammable atmospheres. Ensure that the leak detection equipment being used is suitable for use with all applicable refrigerants: non-sparking, adequately sealed, or intrinsically safe.
6	If conducting any hot work on the refrigerating equipment or any associated parts, you must have appropriate fire-extinguishing equipment on hand. Have a dry powder or CO ₂ fire extinguisher adjacent to the charging area.
7	If conducting work in relation to the refrigerating system that involves exposing any pipework, do not use any sources of ignition in such a manner that may lead to the risk of fire or explosion. All possible ignition sources, including cigarette smoking, must be kept sufficiently far away from the site of installation, repair, removal, and disposal, during which refrigerant might possibly be released to the surrounding space. Before conducting any work, survey the area around the equipment to ensure that there are no flammable hazards or ignition risks. Display "No Smoking" signs.
8	Ensure the area is in the open or that it is adequately ventilated before opening the system or while conducting any hot work. The ventilation must safely disperse any released refrigerant and preferably expel it externally into the atmosphere.
9	Ensure that the sensor is not obstructed in any way.

Room size requirements

WARNING

If the unit must be installed in a residence with a minimum room area less than what is determined to be the minimum from [Table 2](#), then that room must also not have any continuously operating open flames or other potential ignition sources. A device with a continuous pilot light may be present if that device is provided with an effective flame arrest.

Table 2: Minimum room area

System charge (lb - oz)	Minimum room area (ft ²)	Minimum total conditioned room area (ft ²) (Z)	Minimum total conditioned room area (m ²) (Y)	Minimum airflow (CFM)
4-0	200	120	11.14	216
5-0	250	150	13.93	271
6-0	300	180	16.72	325
7-0	350	210	19.50	379
8-0	400	240	22.29	433
9-0	450	270	25.08	487
10-0	499	300	27.86	541
11-0	549	330	30.65	595
12-0	599	360	33.43	649
13-0	649	390	36.22	704
14-0	699	420	39.01	758
15-0	749	450	41.79	812
16-0	799	480	44.58	866
17-0	849	510	47.37	920
18-0	899	540	50.15	974
19-0	949	570	52.94	1028
20-0	999	600	55.72	1082
21-0	1049	630	58.51	1136

① Note:

- Minimum total conditioned room area refers to the combined area of all air conditioned rooms in the residence.

If the system charge is not listed in the above table, use the formulas below to calculate the respective values:

- Minimum conditioned room area (ft²) = system charge x 29.9903
- Minimum conditioned room area (m²) = system charge x 2.786
- Minimum system airflow (CFM) = system charge x 54.117

Mechanical ventilation**Table 3: Mechanical ventilation**

Item number	Safety consideration
1	If installing the unit in a residence below the determined total conditioned area from , then extra mechanical ventilation is required.

Refrigerant equipment checks

Table 4: Refrigerant equipment checks

Item number	Safety consideration
1	Where electrical components are being changed, they must be fit for the purpose and to the correct specification. At all times, the manufacturer's maintenance and service guidelines must be followed. If in doubt, consult the manufacturer's technical department for assistance.
2	Apply the following checks to installations using flammable refrigerants: <ul style="list-style-type: none"> • Ensure the actual refrigerant charge is in accordance with the room size within which the refrigerant-containing parts are installed. • Ensure the ventilation machinery and outlets are operating adequately and are not obstructed. • Ensure marking on the equipment continues to be visible and legible. Correct any markings and signs that are illegible. • Install refrigerating pipe or components in a position where they are unlikely to be exposed to any substance that may corrode refrigerant-containing components, unless the components are constructed of materials that are inherently resistant to being corroded or are suitably protected against being corroded.

Electrical devices checks

Table 5: Electrical devices checks

Item number	Safety consideration
1	Repair and maintenance to electrical components must include initial safety checks and component inspection procedures.
2	If a fault exists that could compromise safety, then do not connect any electrical supply to the circuit until the fault is satisfactorily dealt with. If the fault cannot be corrected immediately but it is necessary to continue operation, use an adequate temporary solution. This must be reported to the owner of the equipment so all parties are advised.
3	Initial safety checks must include: <ul style="list-style-type: none"> • Ensure capacitors are discharged: take care to avoid the possibility of sparking. • Ensure no live electrical components and wiring are exposed while charging, recovering, or purging the system. • Ensure there is continuity of earth bonding.

Detection of refrigerant

Table 6: Detection of refrigerant

Item number	Safety consideration
1	Under no circumstances shall potential sources of ignition be used in the searching for or detection of refrigerant leaks. Do not use a halide torch or any other detector using a naked flame.
2	<p>The following leak detection methods are deemed acceptable for all refrigerant systems.</p> <ul style="list-style-type: none"> • Electronic leak detectors may be used to detect refrigerant leaks but, in the case of flammable refrigerants, the sensitivity may not be adequate or may need re-calibration. Calibrate the detection equipment in a refrigerant-free area. Ensure that the detector is not a potential source of ignition and is suitable for the refrigerant used. Set leak detection equipment at a percentage of the LFL of the refrigerant and calibrate to the refrigerant employed. Ensure the appropriate percentage of gas with a maximum of 25% is confirmed. • Leak detection fluids are also suitable for use with most refrigerants but avoid the use of detergents containing chlorine as the chlorine may react with the refrigerant and corrode the copper pipework. Examples of leak detection fluids are bubble method and fluorescent method agents.
3	If a leakage of refrigerant is found that requires brazing, recover all of the refrigerant from the system or isolate the leakage by means of shut-off valves in a part of the system remote from the leak. Remove refrigerant according to the <i>Removal and evacuations</i> section of the outdoor unit's <i>Installation Manual</i> .

Decommissioning

Before you begin:

Before attempting the procedure, complete the following:

- Ensure that the technician is completely familiar with the equipment and all its detail.
- Ensure to safely recover all refrigerants.
- Take an oil and refrigerant sample, in case analysis is required before reusing the recovered refrigerant.
- Ensure that electrical power is available.
- Ensure that mechanical handling equipment is available, if required, for handling refrigerant cylinders.
- Ensure that all personal protective equipment is available and being used correctly.
- Ensure that the recovery process is supervised at all times by a competent person.
- Ensure that recovery equipment and cylinders conform to the appropriate standards.

Follow the steps below to ensure the unit is correctly and safely decommissioned:

1. Isolate the system electrically.
2. Connect a recovery machine to remove refrigerant from the system.
3. Ensure that the cylinder is situated on the scales before recovery takes place.
4. Start the recovery machine and operate in accordance with instructions provided with the machine.

Note:

- Do not overfill cylinders to more than 80% volume liquid charge.
 - Do not exceed the maximum working pressure of the cylinder, even temporarily.
5. When the cylinders have been filled correctly and the process completed, ensure that the cylinders and the equipment are removed from the site promptly and that all isolation valves on the equipment are closed off.

- ① **Note:** Do not charge recovered refrigerant into another refrigerating system unless it has been cleaned and checked.

Label the equipment stating that it has been decommissioned and emptied of refrigerant. Date and sign the label. For appliances containing flammable refrigerants, ensure that there are labels on the equipment stating that the equipment contains a flammable refrigerant.

Preparing for installation

Complete the necessary preparation before you begin the installation:

1. Visit the installation site to select a suitable location for the outdoor unit, plan the refrigerant piping system, and determine which VH4 outdoor unit model to install.
2. Inspect the outdoor unit.
3. Follow the requirements for transporting and handling the outdoor unit to avoid damage to the unit.
4. Make sure that you are aware of the installation and operation limitations.
5. Familiarize yourself with the requirements for installing or servicing R-454B equipment and make sure you have all necessary equipment.
6. Source any additional parts required for the specific installation.

Selecting a location for installation

Before starting the installation, you must select a suitable location for the outdoor unit. You can install the outdoor unit on the ground, on a roof, or on a wall.

- ① **Note:** For more information about selecting a suitable location for the indoor unit, refer to the *Installation Manual* for the indoor unit.

WARNING

The outdoor unit must not be installed in an area where mud or ice could cause personal injury.

- **Important:** Avoid the following places for installation where damage to the outdoor unit may occur:
- Where there is machine oil
 - Coastal regions where the equipment is prone to atmospheric corrosion
 - Near hot springs where the equipment is prone to sulfide gas corrosion
 - In proximity to high-frequency or wireless equipment

To select a location for installation, do the following:

- Select a location for the outdoor unit that meets the following general requirements for installation:
 - Limits the exposure of the outdoor unit to wind, rain, snow accumulation, and direct sunlight.
 - Is away from bedroom windows or other room windows where the sound of the unit operation might be objectionable.
 - Provides ample clearance from shrubs. This is necessary to allow adequate air to pass across the outdoor coil without leaves or branches being pulled into the fan.
 - Allows sufficient clearance for air entrance to the outdoor coil, air discharge, and service access.

- Allows you to elevate the unit sufficiently to prevent any blockage of the air entrances by snow in areas where snow may accumulate. Check the local weather bureau for the expected snow accumulation in your area.
- Is isolated from rain gutters to avoid any possible wash out of the foundation.
- Enables you to keep the length of the refrigerant tubing between the outdoor unit and the indoor coil as short as possible to avoid capacity and efficiency losses. You must observe all limitations and clearance requirements.
- Allows you to install the unit horizontally in a level position and maintain the minimum clearances shown in Figure 1 or Figure 2.

Figure 1: Minimum clearances when selecting a location for installation of VH412E2S11/VH418E2S11/VH424E2S11/VH430E2S11/VH436E2S11

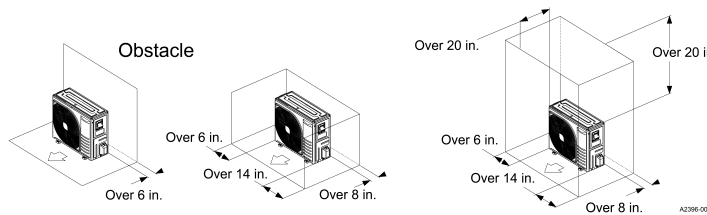

Figure 2: Alternative installation clearances for multiple units for installation of VH412E2S11/VH418E2S11/VH424E2S11/VH430E2S11/VH436E2S11

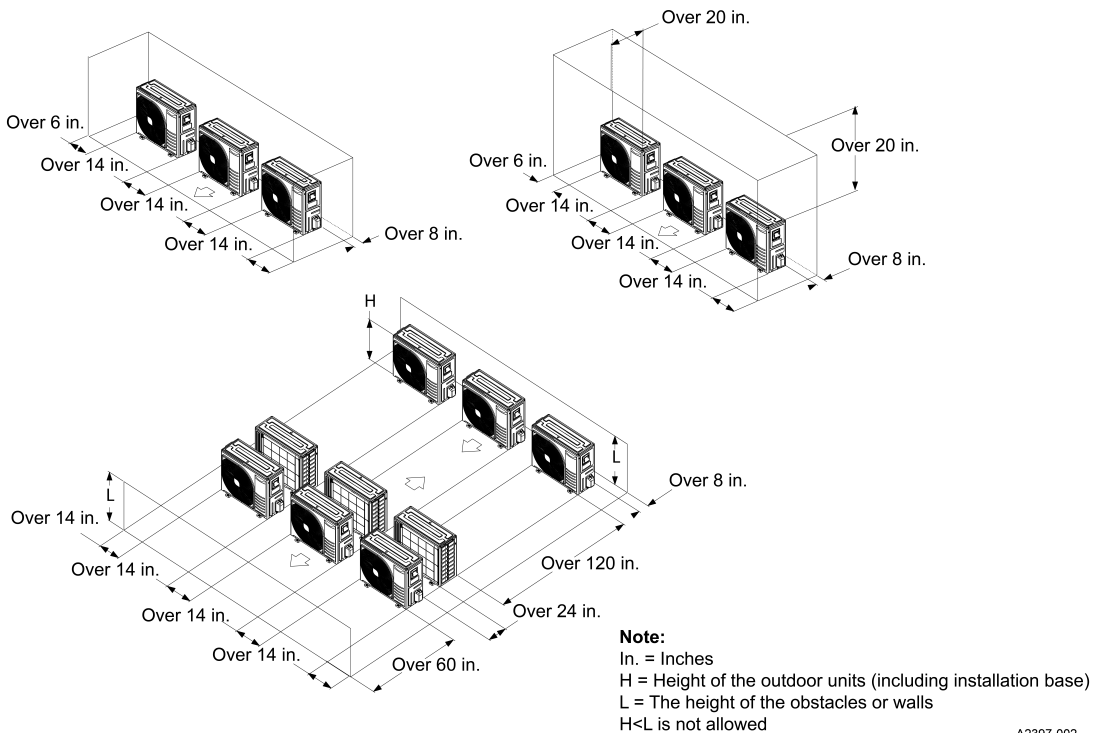
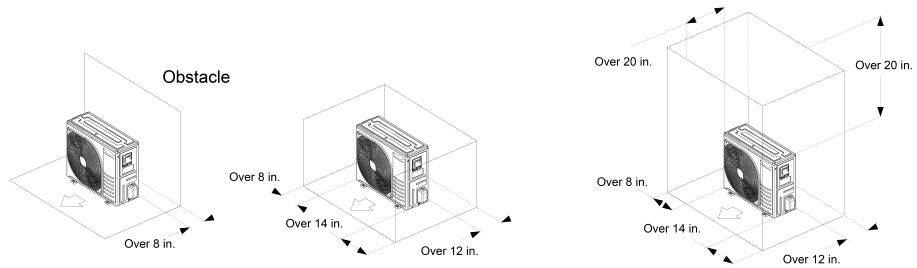
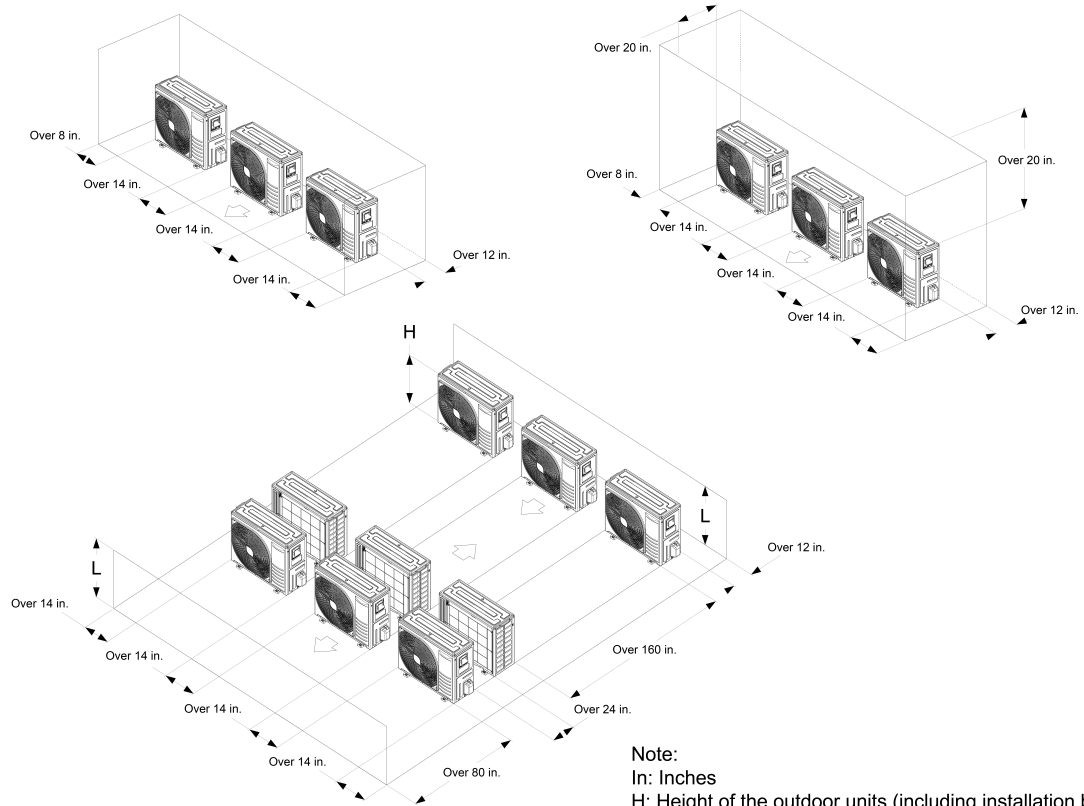

Figure 3: Installation clearances when selecting location for VH442E2S11/VH448E2S11/VH460E2S11 - single or multiple units

When installing a unit



When two or more outdoor units are installed side by side.



Note:
 In: Inches
 H: Height of the outdoor units (including installation base)
 L: The height of obstacles or walls
 H<L is not allowed

A2516-001

- Select a location for the outdoor unit that meets any requirements that are specific to the type of installation as outlined in [Table 7](#).

Table 7: Additional location requirements for each type of installation

Type of installation	Additional location requirements
Ground installation	<ul style="list-style-type: none"> The location of the outdoor unit allows you to install and anchor the outdoor unit on a strong, solid base that positions the outdoor unit in a level position at least 4 in. above grade and does not shift or settle, which could cause strain on the refrigerant lines and possible leaks. There is sufficient space for the base. The base must not come in contact with the foundation or side of the structure because sound may transmit to the residence.
Roof installation	<ul style="list-style-type: none"> The location of the outdoor unit allows you to install and anchor the outdoor unit on a strong, solid base that positions the outdoor unit in a level position at least 4 in. from the roof. There is sufficient space for the base. The structure is capable of supporting the total weight of the outdoor unit, including a base, lintels, and rails. You must use a base, lintels, and rails to minimize the transmission of sound or vibration to the structure. The location of the outdoor unit ensures that there is minimal transmission of sound and vibration to the structure.
Wall-mounted installation	<ul style="list-style-type: none"> Mounting the outdoor unit does not cause a loss of structural integrity. The location of the outdoor unit allows you provide adequate support for the base pan and mount the unit in a level position. The outdoor unit can be accessed safely when mounted, for example, for servicing. The location of the outdoor unit ensures that there is minimal transmission of sound and vibration to the structure.

Planning the refrigerant piping system

Before starting the installation, plan the refrigerant piping system carefully to ensure that the system operates correctly and efficiently. This allows you to determine the refrigerant piping length, which you need to know to select which VH4 outdoor unit model to install. See [Selecting the outdoor unit model](#).

ⓘ Note:

- As per DOE testing, the unit is provided with a charge for 25 ft. If the field supplied refrigerant piping is 15 ft in length, subtract the amount of refrigerant to account for the difference in the actual refrigerant piping length for the field installation. See [Table 8](#) and [Adjusting refrigerant charge](#) for charging requirements and more information about charging the refrigerant.

To plan the refrigerant piping system, do the following:

- Note the maximum refrigerant piping length and height difference allowed between the indoor and outdoor units. See [Figure 4](#), [Figure 5](#), and [Table 8](#).
- Determine the refrigerant piping layout, making sure that the length of the refrigerant piping between the indoor and outdoor units is as short as possible to optimize system performance.

Selecting the outdoor unit model

Before you begin:

Plan the refrigerant piping system and determine the length of the refrigerant piping. See [Planning the refrigerant piping system](#).

Before starting the installation, you must select which VH4 outdoor unit model to install based on the following:

- Perform a load calculation on the structure and compare the requirements to the system performance data found in the unit *Technical Guide*.
- The actual length of the refrigerant piping and any height difference between the position of the indoor and outdoor units
- How the equivalent length of the refrigerant piping and any height difference between the position of the indoor and outdoor units impacts the heating and cooling capacity of the system
- How defrost operation impacts the heating capacity of the system if applicable

Refer to the VH4 *Technical Guide* for a detailed overview of system capacity for specific indoor and outdoor unit configurations. In this procedure, be aware of the following:

- L refers to the actual one-way refrigerant piping length between the indoor and outdoor units in feet or meters.
- H refers to the height difference between the indoor and outdoor units in feet or meters. If $H > 0$, the position of the outdoor unit is higher than the position of the indoor unit. If $H < 0$, the position of the outdoor unit is lower than the position of the indoor unit.
- EL refers to the equivalent one-way refrigerant piping length between the indoor and outdoor units in feet or meters.

► **Important:** If the specific installation includes more than one indoor unit, make sure that you consider the indoor unit that is farthest from the outdoor unit when completing the steps.

To select the outdoor unit model, do the following:

1. Use [Table 8](#) to check which VH4 outdoor unit models are suitable for your specific installation based on the actual length of the refrigerant piping between the indoor and outdoor units and any height difference between the indoor and outdoor units.

Figure 4: Refrigerant piping with outdoor unit lower than indoor unit

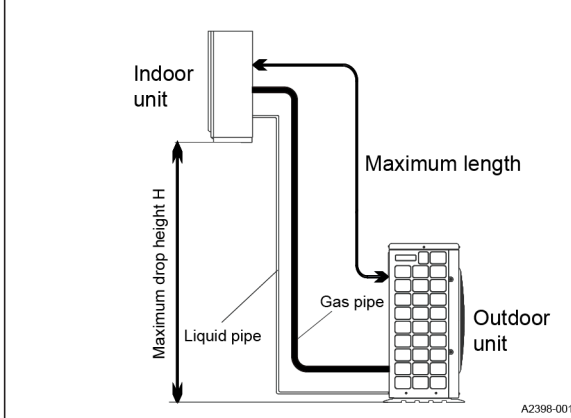

Figure 5: Refrigerant piping with outdoor unit higher than indoor unit

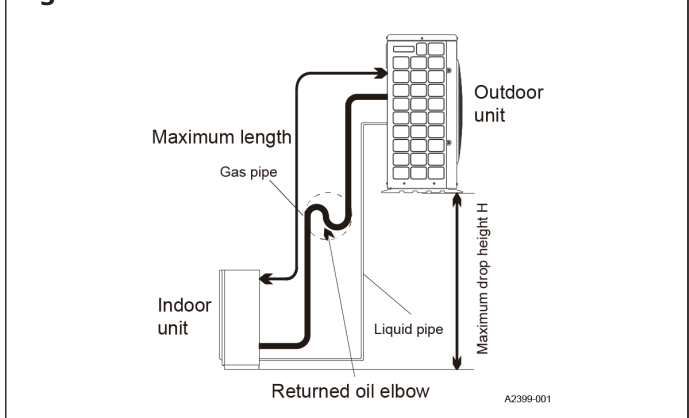

Table 8: Refrigerant piping

Outdoor unit model	Maximum refrigerant piping length (L)	Maximum height difference (H)	Additional refrigerant - exceeding 25 ft (7.6 m)	Additional oil	Oil type
	ft (m)	ft (m)	oz/ft		
VH412E2S11	148 (45)	66 (20)	0.38 oz/ft	After 82ft (25m) 0.068 oz/ft (6.7 ml/m)	FW68L - PVE based oil
VH418E2S11	148 (45)	66 (20)	0.38 oz/ft	After 98ft (30m) 0.144 oz/ft (14ml/m)	FW68L - PVE based oil
VH424E2S11	148 (45)	66 (20)	0.38 oz/ft	After 98ft (30m) 0.144 oz/ft (14ml/m)	FW68L - PVE based oil
VH430E2S11	180 (55)	82 (25)	0.38 oz/ft	After 115ft (35m) 0.083 oz/ft (8ml/m)	VG74 - POE based oil
VH436E2S11	180 (55)	82 (25)	0.38 oz/ft	After 115ft (35m) 0.083 oz/ft (8ml/m)	VG74 - POE based oil
VH442E2S11	213 (65)	98 (30)	0.38 oz/ft	After 131ft (40m) 0.091 oz/ft (9ml/m)	VG74 - POE based oil
VH448E2S11	213 (65)	98 (30)	0.38 oz/ft	After 131ft (40m) 0.091 oz/ft (9ml/m)	VG74 - POE based oil
VH460E2S11	213 (65)	98 (30)	0.38 oz/ft	After 131ft (40m) 0.091 oz/ft (9ml/m)	VG74 - POE based oil

Note:

- For FW68L, use Nu-Calgon FVC68D (P/N 4319-24) or equivalent.
- For VG74, use Nu-Calgon RL68H (P/N 4316-44) or equivalent.

2. Use [Table 9](#) to calculate the equivalent length of the refrigerant piping elbows for your specific installation.

Table 9: Equivalent length of elbows in feet

Gas diameter - in. (mm)	90° elbow - ft (cm)
3/8 (9.52)	0.80 (24.38)
5/8 (15.88)	1.3 (39.62)
3/4 (19.05)	1.4 (42.67)
7/8 (22.22)	1.6 (48.77)

3. Add the equivalent length of the refrigerant piping elbows to the actual length of the refrigerant piping to calculate the equivalent length of the refrigerant piping.
4. Use [Table 10](#) to determine how the equivalent length of the refrigerant piping impacts the cooling capacity of the system as follows:
 - If the position of the outdoor unit is at the same height or less than 16 ft above the position of the indoor unit, use the relevant values shown in [Table 10](#).

Table 10: Cooling capacity correction factors

EL - ft (m)	VH412E2S11	VH418E2S11	VH424E2S11	VH430E2S11	VH436E2S11	VH442E2S11	VH448E2S11	VH460E2S11
25(7.6)	1.00	1.00	1.00	1.00	1.00	1.00	1.00	1.00
38(10)	0.95	0.95	0.95	0.98	0.98	0.98	0.98	0.98
50(15)	0.93	0.93	0.93	0.97	0.97	0.97	0.97	0.97
75(23)	0.89	0.89	0.89	0.93	0.93	0.93	0.93	0.93
100(30)	0.85	0.85	0.85	0.89	0.89	0.89	0.89	0.89
124(38)	0.81	0.81	0.81	0.86	0.86	0.86	0.86	0.86
150(45)	0.75	0.75	0.75	0.82	0.82	0.82	0.82	0.82

Table 10: Cooling capacity correction factors

EL - ft (m)	VH412E2S11	VH418E2S11	VH424E2S11	VH430E2S11	VH436E2S11	VH442E2S11	VH448E2S11	VH460E2S11
180(55)	—	—	—	0.77	0.77	0.77	0.77	0.77
200(61)	—	—	—	—	—	0.65	0.65	0.65
246(75)	—	—	—	—	—	—	—	—

For example, if the equivalent length of the refrigerant piping is 38 ft, systems with VH418E2S11 and VH424E2S11 outdoor units operate at 95% of listed cooling capacity and systems with VH430E2S11 outdoor units operate at 98% of listed cooling capacity.

- If the position of the outdoor unit is 16 ft or more above the position of the indoor unit, apply the appropriate height correction factor in [Table 11](#) to the relevant values shown in [Table 10](#).

Table 11: Height correction factors

Height difference between indoor and outdoor units - ft (m)	Correction factor
16(5)	0.01
33(10)	0.02
108(30)	0.025

For example, if the equivalent length of the refrigerant piping is 38 ft and the position of the outdoor unit is 16 ft above the position of the indoor unit, systems with VH418E2S11 and VH424E2S11 outdoor units operate at 94% of listed cooling capacity and systems with VH430E2S11 outdoor units operate at 97% of listed cooling capacity.

- Use [Table 12](#) to determine how the equivalent length of the refrigerant piping impacts the heating capacity of the system as follows:
 - If the position of the outdoor unit is at the same height or less than 16 ft below the position of the indoor unit and you do not need to consider defrost operation, use the relevant values in [Table 12](#).

Table 12: Heating capacity correction factors

EL - ft (m)	VH412E2S11	VH418E2S11	VH424E2S11	VH430E2S11	VH436E2S11	VH442E2S11	VH448E2S11	VH460E2S11
25(7.6)	1.00	1.00	1.00	1.00	1.00	1.00	1.00	1.00
38(10)	0.95	0.95	0.95	0.98	0.98	0.98	0.98	0.98
50(15)	0.93	0.93	0.93	0.97	0.97	0.97	0.97	0.97
75(23)	0.89	0.89	0.89	0.93	0.93	0.94	0.94	0.94
100(30)	0.85	0.85	0.85	0.89	0.89	0.90	0.90	0.90
124(38)	0.81	0.81	0.81	0.86	0.86	0.86	0.86	0.86
150(45)	0.75	0.75	0.75	0.83	0.83	0.83	0.83	0.83
180(55)	—	—	—	0.77	0.77	0.80	0.80	0.80
200(61)	—	—	—	—	—	0.75	0.75	0.75
246(75)	—	—	—	—	—	—	—	—

For example, if the equivalent length of the refrigerant piping is 38 ft, systems with VH418E2S11 and VH424E2S11 outdoor units operate at 94% of listed heating capacity and systems with VH430E2S11 outdoor units operate at 98% of listed heating capacity.

- If the position of the outdoor unit is 16 ft or more below the position of the indoor unit, apply the appropriate height correction factor in [Table 11](#) to the relevant values in [Table 12](#).

For example, if the equivalent length of the refrigerant piping is 38 ft and the position of the outdoor unit is 16 ft below the position of the indoor unit, systems with VH418E2S11 and VH424E2S11 outdoor units operate at 93% of listed heating capacity and systems with VH430E2S11 outdoor units operate at 97% of listed heating capacity.

- If you need to correct the heating capacity to include defrost operation, apply the appropriate defrost operation correction factor to the relevant values in [Table 12](#) using the following equation: corrected heating capacity = defrost correction factor x unit capacity.
6. Select the most suitable VH4 outdoor unit model to install based on the refrigerant piping length, any height difference between the indoor and outdoor units, and cooling and heating capacity considerations.

Accessories for long pipe installation

Long refrigerant piping increases the risk of pressure drop, liquid migration, poor oil return, and compressor failure. Use the following accessories to stabilize the system performance for refrigerant piping that exceeds the typical allowable standard pipe lengths.

Consider the following before installing long refrigerant piping:

Note:

1. Installation must be performed only by a trained and authorized HVAC technician familiar with refrigerant piping standards.
2. Install the refrigerant lines with minimum bends, avoiding kinks and unnecessary elevation changes.
3. Ensure that the vapor and liquid lines are insulated.
4. Before installation, calculate the total equivalent length including elbows, traps, valves, and fittings.
5. Using a larger than specified line size could result in oil return problems. Using too small a line results in a loss of capacity and other problems caused by insufficient refrigerant flow. Horizontal refrigerant vapor lines between the indoor unit and the outdoor unit must slope towards the outdoor unit at approximately 1/8 in/ft to facilitate sufficient oil return.

Additional refrigerant and oil charge

1. For long line length exceeding a length of 25 ft (7.6 m), add an additional refrigerant charge of **0.38 oz/ft** into the system.
2. For additional compressor oil charge, refer to [Table 8](#) for the respective models and type of oil.

Accessories for long refrigerant piping installations

1. **Crankcase heater (part of the system)** - A crankcase heater will warm the compressor sump and prevent the refrigerant migration and dilution of the compressor oil during the off cycle.
2. **Oil traps (vertical risers) in the vapor line**
 - When the indoor unit is lower than the outdoor unit and the height difference is more than 16 ft, you must install an oil trap every 16 ft in the vapor line.
 - Oil traps ensure oil return through tall vertical lifts and maintains compressor lubrication.

To install oil traps in the vapor line, do the following:

- a. Measure 16 ft on the vapor line.
- b. Install the oil trap at the 16 ft mark in line with the following:
 - Keep the oil trap as short and straight as possible to avoid storing too much oil in the oil trap and ensure better cooling and heating performance.
 - Make sure that the horizontal piping slopes towards the oil trap or the outdoor unit at a slope of 1/8 in/ft for sufficient oil return.
- c. If the vapor line is longer than 16 ft, install an oil trap every additional 16 ft in the vapor line.

Figure 6: Oil traps

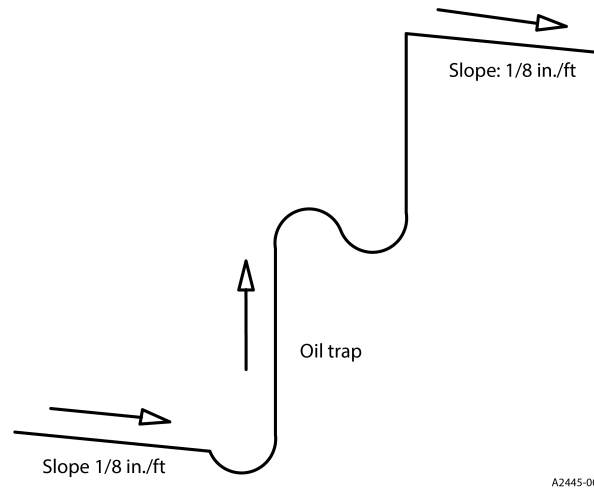

Inspecting the unit

1. Inspect the unit immediately after receiving it for possible damage during transit, including copper distributor lines that may have shifted and are touching either copper lines or the cabinet.
2. If damage is evident, do the following:
 - a. Note the extent of any damage on the carrier's receipt.
 - b. Make a separate written request for the carrier's agent to inspect the unit.
 - c. Contact the local distributor for more information.

Transporting and handling the unit

1. Route two lifting slings under the unit as shown in [Figure 7](#). If there are no packaging materials, protect the unit with cloth or paper. See [Figure 8](#).

Figure 7: Handling with packaging

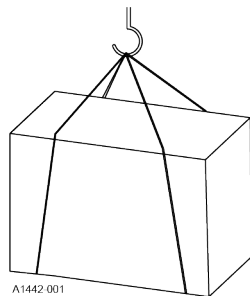
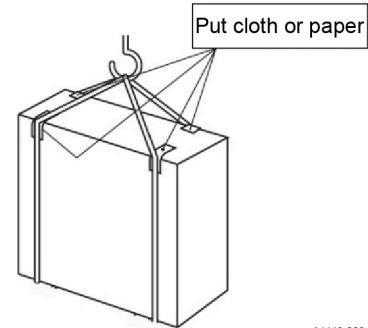

Figure 8: Handling without packaging



2. Ensure the unit is balanced and, if safe to do so, carefully lift up the unit.

Understanding installation and operation limitations

Install the outdoor unit in accordance with all national, state, and local safety codes and the following requirements:

- Observe the limitations for the indoor unit, coil, and appropriate accessories.

Preparing for installation

- Do not install the outdoor unit with any ductwork in the air stream. The outdoor fan is a propeller fan and is not designed to operate against any additional external static pressure.
- Observe the maximum and minimum conditions for operation to ensure the system gives maximum performance and requires minimum service. See [Table 13](#).

Table 13: Minimum and maximum operating limit conditions

Air temperature	Outdoor coil °F (°C)	
	DB cool	DB heat
Minimum	35 (2)	-5 (-21)
Maximum	120 (49)	75 (24)

Failure to observe the maximum and minimum operating conditions can lead to reduced capacity. Read the following notices for more information.

NOTICE

Inverter temperature protection

If excessive inverter temperatures are sensed, the compressor speed and capacity are reduced until an acceptable condition is reached. When the inverter temperature returns to an acceptable level, the system returns to normal operation.

NOTICE

Low ambient protection

Cooling mode: The unit automatically adjusts to maintain cooling operation in outdoor ambient conditions down to 35°F (2°C). The unit reduces capacity and low ambient protection (cooling mode) or cycles off if asked to provide cooling when the outdoor temperature is at or below these conditions. Heating mode: The unit provides compressor heat down to an outdoor ambient temperature of -5°F (-21°C). As the outdoor ambient temperature reduces, available heat reduces for all air source heat pumps.

NOTICE

Overcurrent and undercurrent protection

If a low or high current condition is sensed, the compressor speed and capacity are reduced until an acceptable current level is reached. When the system reaches an acceptable current level, the compressor and fan return to normal operating conditions.

NOTICE

Overvoltage and undervoltage protection

If a low or high supply voltage condition is sensed (below 187 VAC or above 253 VAC), the compressor speed and capacity are automatically reduced until an acceptable voltage level is reached. When an acceptable voltage level is sensed, the system automatically returns to a normal state of operation.

Meeting requirements for R-454B equipment

Make sure that you have all necessary equipment before you begin the installation. You must adhere to the following requirements when installing or servicing R-454B equipment:

- Gauge sets, hoses, refrigerant containers, and recovery system must be designed to handle the POE type oils and higher pressures of R-454B.
- Manifold gauge sets must be high side and low side with low side retard.
- All hoses must have a 700 psig service pressure rating.
- Electronic leak detectors can be used for detecting refrigerant leaks. For flammable refrigerants, check the sensitivity and potentially recalibrate the detector.
- Leak detection fluids are also suitable for use with most refrigerants. Avoid using detergents containing chlorine, as they can react with refrigerants and corrode copper pipework. Examples of leak detection methods include the bubble method and fluorescent agents.
- Recovery equipment, including refrigerant recovery containers, must be specifically designed to handle R-454B.
- Do not use an R-22 or R-410A TXV.
- If an indirect refrigerating circuit is used, inspect the secondary circuit for refrigerant presence.
- Maintain visible and legible markings on the equipment. Illegible markings or signs should be corrected.
- Install refrigerating pipes and components in locations where they are unlikely to be exposed to corrosive substances, unless the components are made from corrosion-resistant materials or adequately protected against corrosion.

Sourcing additional parts

Make sure that you have all additional parts required before you begin the installation.

- Use an R-454B TXV. See the *Tabular Data Sheet* for suitable models.
- Use a field-supplied R-454B liquid-line filter drier.

Install the outdoor unit.

Installing the outdoor unit

There are three installation options for the outdoor unit: ground installation, roof installation, and wall-mounted installation. You must follow all requirements for the specific type of installation.

If you are installing the outdoor unit as a replacement for an existing R-454B unit, follow the procedure outlined in [Installing the outdoor unit as a replacement unit](#).

To install the outdoor unit correctly, you must do the following:

1. Make sure that you are familiar with the requirements for installation in low-ambient conditions if applicable.
2. For wall-mounted installations, install the drain elbow and drain hose. This is required to avoid adverse conditions in the area around the outdoor unit unless the climate is too cold for the drain elbow and drain hose to operate correctly.
3. Set the outdoor unit on the ground or roof or mount the outdoor unit on a wall.
4. Affix the brand label to the outdoor unit.

Installing the outdoor unit as a replacement unit

When installing the outdoor unit as a replacement for an existing R-454B outdoor unit, you must replace the indoor coil and the outdoor unit because these are matched systems. Complete all of the steps outlined to ensure

correct system operation and performance. If you are installing the outdoor unit in low-ambient conditions, see [Understanding requirements for low-ambient conditions](#).

⚠ WARNING

Never install a suction-line filter drier in the liquid line of an R-454B system. Failure to follow this warning can cause a fire, injury, or death.

To install the outdoor unit as a replacement unit, do the following:

1. Remove the existing outdoor unit.
2. Make sure that the location of the outdoor unit you are replacing is suitable for installing the outdoor unit. See [Selecting a location for installation](#).
3. Check that the indoor coil to be installed is a correct match for the outdoor unit.
4. Replace the indoor coil with an approved R-454B coil or air handling unit with the appropriate metering device. Refer to the *Installation Manual* for the indoor unit for more information.
5. For wall-mounted installations, install the drain elbow and drain hose. This is required to avoid adverse conditions in the area around the outdoor unit unless the climate is too cold for the drain elbow and drain hose to operate correctly. See [Installing the drain elbow and drain hose](#).
6. Install the outdoor unit. See [Setting the outdoor unit on the ground or a roof](#) or [Mounting the outdoor unit on a wall](#).
7. Affix the brand label. See [Affixing the brand label](#).
8. Replace the refrigerant piping if the installation conditions require as outlined in [Table 14](#).

Table 14: Replacing refrigerant piping

Installation condition	Approach
You are replacing an outdoor unit that uses R-410A refrigerant. VH4 outdoor units use R-454B refrigerant.	Replace the refrigerant piping to reduce cross-contamination of oils and refrigerants. See . If replacing the refrigerant piping is not practical, take the following precautions: <ol style="list-style-type: none"> 1. Inspect the refrigerant piping for kinks, sharp bends, or other restrictions, and for corrosion. 2. Determine if there are any low spots that might be serving as oil traps. 3. Flush the refrigerant piping with a commercially available flush kit to remove as much of the existing oil and contaminants as possible.
You are replacing the outdoor unit because of a compressor burnout.	Replace the refrigerant piping or, at a minimum, thoroughly flush the refrigerant piping with a commercially available flush kit. See .
The existing refrigerant piping is not the correct size.	Replace the refrigerant piping. See .

Understanding requirements for low-ambient conditions

When installing the outdoor unit for operation in low ambient conditions, you must adhere to the following requirements:

- Do not install the outdoor unit in a place where its air inlet and outlet sides may be exposed directly to wind.
- Install the outdoor unit with its air inlet side facing the wall to prevent exposure to wind.

- Install a baffle board on the air outlet side of the outdoor unit to prevent exposure to wind.

Installing the drain elbow and drain hose

Condensate water may drain from the outdoor unit when the outdoor unit operates in heating mode. For wall-mounted installations, to avoid adverse conditions in the area around the outdoor unit, install the drain elbow and a drain hose to drain out the condensate water. You do not have to install the drain elbow and a drain hose for ground or roof installations. The drain elbow is included with the outdoor unit. The drain hose is field supplied and must have an inside diameter of 15 mm. You must install the drain elbow and drain hose before the indoor and outdoor units are connected.

- **Important:** Do not install a drain elbow and drain hose in colder climates where the drain may freeze and prevent defrost water from leaving the unit.

NOTICE

Heat pumps defrost periodically resulting in water drainage. The unit must not be located where water drainage may freeze and create a hazardous condition, such as sidewalks and steps.

To install the drain elbow and drain hose, do the following:

1. Install the drain elbow as shown in [Figure 9](#).

Figure 9: Drainage

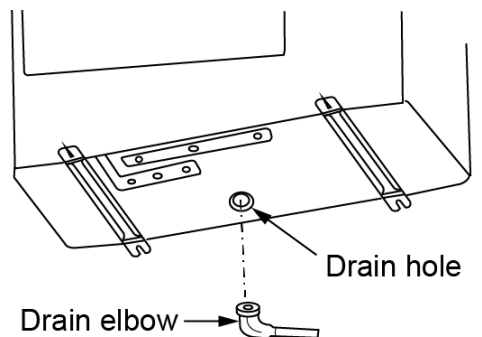

A1444-003

2. Connect the drain hose to the drain elbow.

Setting the outdoor unit on the ground or a roof

Before you begin:

Make sure that the location you have selected for the outdoor unit is suitable. See [Selecting a location for installation](#).

For ground installation, you must use a strong, solid base, that positions the outdoor unit in a level position at least 4 in. from the ground. For roof installation, you must use a strong, solid base that positions the outdoor unit in a level position at least 4 in. from the roof. This keeps the outdoor unit dry and reduces the chance of corrosion, which could reduce the life span of the outdoor unit. For roof installation, you must use a base, lintels, and rails to minimize the transmission of sound or vibration to the structure. If site conditions require, elevate the unit above the base, for example, using riser legs, a stand, or snow legs. If you are installing the outdoor unit in low-ambient conditions, adhere to the requirements outlined in [Understanding requirements for low-ambient conditions](#).

⚠ CAUTION

Do not drain condensate onto public places, because this may lead to slippery surfaces.

- **Important:** If installing the outdoor unit on a hot sun exposed roof or a paved ground area that is seasonally hot, raise the outdoor unit sufficiently above the roof or ground to avoid taking the accumulated layer of hot air into the outdoor unit, which can cause the outdoor unit to derate prematurely.

To set the outdoor unit on the ground or a roof, do the following:

1. Position the base so the outdoor unit is level and at least 4 in. from the ground or roof. See [Figure 10](#).

Figure 10: Base for all VH4 outdoor models

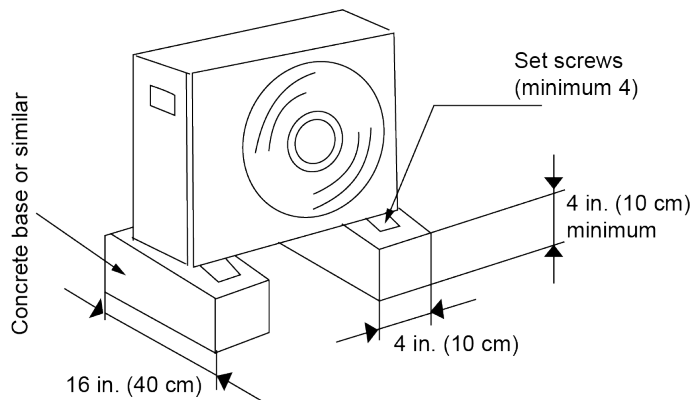

A1447-002

2. Install the anchor bolts into the base so they align with the anchoring position for the outdoor unit as shown in [Figure 11](#) and [Table 15](#).

Figure 11: Anchoring positions

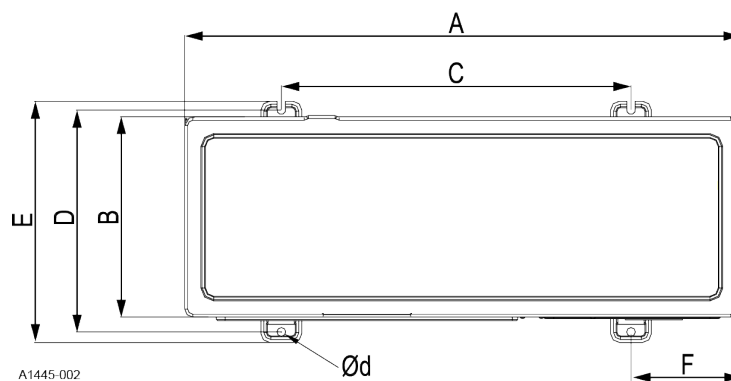

A1445-002

Table 15: Anchoring position measurements

Outdoor unit model	A	B	C	D	E	F	d
	in. (mm)	in. (mm)	in. (mm)	in. (mm)	in. (mm)	in. (mm)	in. (mm)
VH412E2S11	33 7/8	12 3/16	21 3/8	13 7/16	14 1/2	6 5/8 (168)	3/8*5/8 (11*17)
VH418E2S11	(860)	(310)	(542)	(341)	(368)		
VH424E2S11							

Table 15: Anchoring position measurements

Outdoor unit model	A	B	C	D	E	F	d
	in. (mm)	in. (mm)	in. (mm)	in. (mm)	in. (mm)	in. (mm)	in. (mm)
VH430E2S11	35 3/7	13 2/5	24 (608)	14 1/2	15 2/3	5 3/4 (146)	3/8*3/4
VH436E2S11	(900)	(340)		(368)	(398)		(10*20)
VH442E2S11	43 1/4	17 5/7(450)	25 1/5	19 (485)	20 2/7	9 1/4 (235)	1/2*3/4
VH448E2S11	(1100)		(640)		(515)		(12*20)
VH460E2S11							

- Place the outdoor unit in a horizontal position on the base at the anchoring locations.
- Place a washer on each anchor bolt.
- Fasten the outdoor unit tightly to the anchor bolts to secure the outdoor unit as shown in [Figure 12](#).

► **Important:** You must fasten the outdoor unit tightly and in a horizontal position to prevent noise.

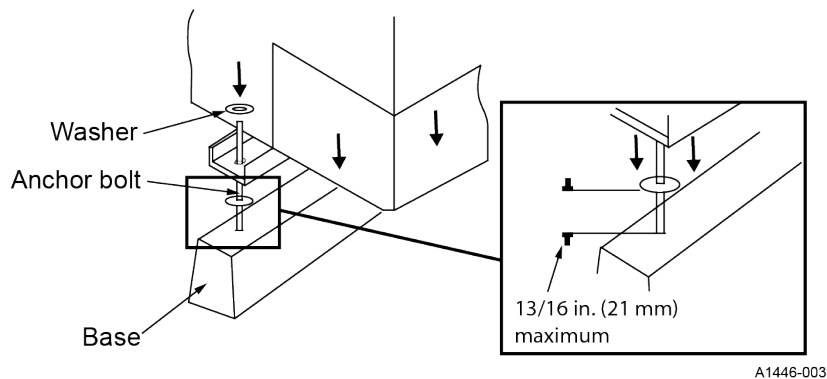
Figure 12: Securing the outdoor unit

- Check the length of the bolts. If the bolts are too long and could impede any future movement of the outdoor unit, cut them to a more appropriate length.

Mounting the outdoor unit on a wall

Before you begin:

Ensure that you have installed the drain elbow and drain hose. This is required for wall-mounted installations unless the climate is too cold for the drain elbow and drain hose to operate correctly. See [Installing the drain elbow and drain hose](#). Make sure that the location you have selected for the outdoor unit is suitable. See [Selecting a location for installation](#).

When site conditions require you to mount the outdoor unit on a wall, you must use two direct wall mount brackets to support the outdoor unit. The wall mount brackets are field supplied. It is important to be aware that wall mounting is best served by a correctly engineered solution. If you are installing the outdoor unit in low-ambient conditions, adhere to the requirements outlined in [Understanding requirements for low-ambient conditions](#).

⚠ CAUTION

Do not drain condensate onto public places, because this may lead to slippery surfaces.

To mount the outdoor unit on a wall, do the following:

- Use two wall mount brackets to mount the outdoor unit in a level position on the wall.

Affixing the brand label

1. Find the brand label in the plastic bag attached to the outdoor unit carton.
2. Remove the label backing and affix the brand label in the area on the outdoor unit marked A in [Figure 13](#), centered 1/2 in. immediately below the tooling mark on the front panel.

Figure 13: Brand label location

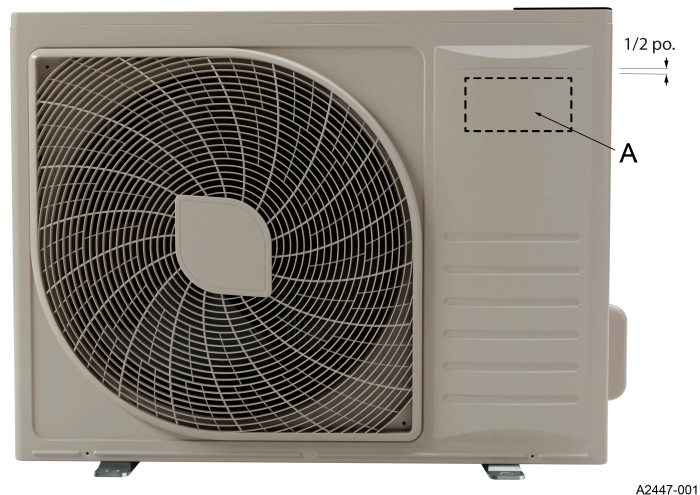

Installing the refrigerant piping

To install the refrigerant piping correctly, you must do the following:

1. Install the vapor line and the liquid line.
2. Install an oil trap every 16 ft in the vapor line if the installation conditions require.
3. Install a liquid-line filter drier on the liquid line.
4. Braze the refrigerant lines and service valves.
5. Check the refrigerant system for leaks.
6. Evacuate the refrigerant lines and the indoor coil.
7. Release the refrigerant into the system.
8. Charge the refrigerant as required for the outdoor unit model if the refrigerant piping is longer than 25 ft.

Installing the vapor and liquid lines

Before you begin:

Make sure that you have planned the refrigerant piping system before you install the refrigerant lines. See [Planning the refrigerant piping system](#).

⚠ CAUTION

When installing refrigerant piping through the wall, keep the piping capped to prevent debris from entering. Do not place the pipe directly on the ground.

To install the vapor and liquid lines, do the following:

- Connect the outdoor unit to the indoor coil using field-supplied refrigerant grade (ACR) copper tubing that is internally clean and dry. You must install units with only the tubing sizes for approved system combinations as specified in the *Tabular Data Sheet*. The charge given is applicable for total tubing lengths up to 25 ft (7.62 m).
- Install the refrigerant lines with as few bends as possible. Make sure not to damage the couplings or kink the tubing. Use clean hard-drawn copper tubing where no appreciable amount of bending around obstruction is necessary. If you must use soft copper, make sure to avoid sharp bends that may cause a restriction.
- Install the refrigerant lines so that they do not obstruct service access to the coil, indoor unit, or filter.
- Isolate the refrigerant lines to minimize noise transmission from the equipment to the structure.
- Make sure that the vapor line is insulated with a minimum of 1/2 in. foam rubber insulation such as Armaflex or an equivalent. Make sure that the liquid line is insulated if it may be exposed to direct sunlight, high temperatures, or excessive humidity.
- Tape and suspend the refrigerant lines correctly. Do not allow tube metal-to-metal contact. See [Figure 14](#).

Figure 14: Installation of vapor line

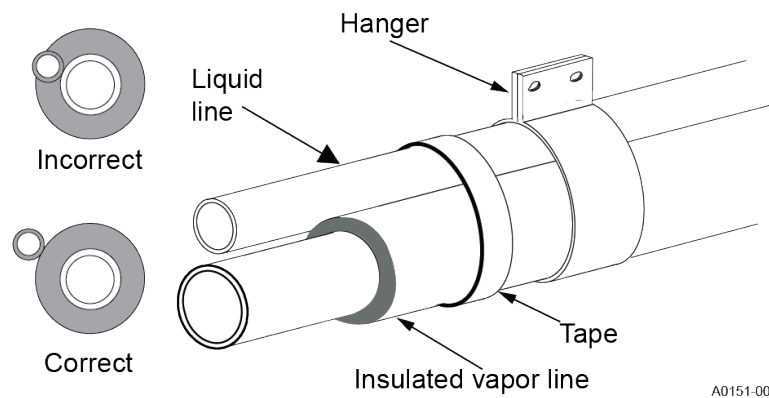

- Use PVC piping as a conduit for all underground installations as shown in [Figure 15](#). Keep buried lines as short as possible to minimize the build up of liquid refrigerant in the vapor line during long periods of shutdown.

Figure 15: Underground installation

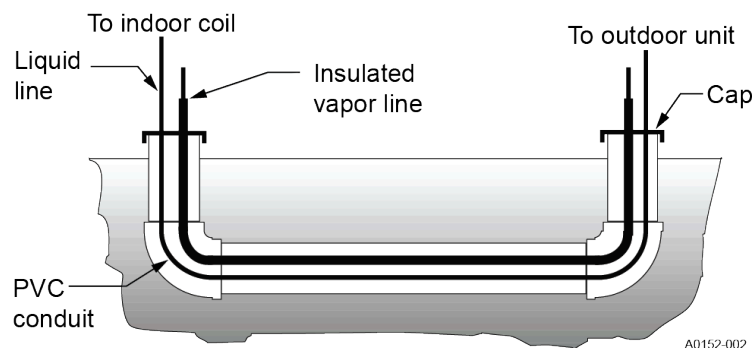

- Pack fiberglass insulation and a sealing material such as permagum around refrigerant lines where they penetrate a wall to reduce vibration and retain some flexibility.

Installing oil traps in the vapor line

When the indoor unit is lower than the outdoor unit and the height difference is more than 16 ft, you must install an oil trap every 16 ft in the vapor line.

Figure 16: Oil trap

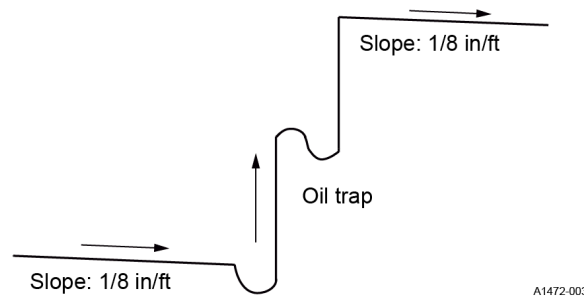

To install oil traps in the vapor line, do the following:

1. Measure 16 ft on the vapor line.
2. Install the oil trap at the 16 ft mark in line with the following:
 - Keep the oil trap as short and straight as possible to avoid storing too much oil in the oil trap and ensure better cooling and heating performance.
 - Make sure that the horizontal piping slopes toward the oil trap or outdoor unit at a slope of 1/8 in/ft for sufficient oil return.
3. If the vapor line is longer than 16 ft, install an oil trap every additional 16 ft in the vapor line.

Installing the liquid-line filter drier

You must install an R-454B bi-flow liquid-line filter drier external to the outdoor unit. The indoor unit must be in place before you install the field-supplied R-454B liquid-line filter drier.

NOTICE

Using a larger than specified line size could result in oil return problems. Using too small a line results in loss of capacity and other problems caused by insufficient refrigerant flow. Horizontal refrigerant vapor lines between the indoor unit and the outdoor unit must slope towards the outdoor unit at approximately 1/8 in/ft to facilitate sufficient oil return.

To install the liquid-line filter drier, do the following:

1. Find a suitable location on the liquid line near the indoor unit.
2. Install the bi-flow liquid-line filter drier in accordance with the installation instructions for the liquid-line filter drier.

Brazing the refrigerant lines and service valves

It is important to take the necessary precautions for brazing the refrigerant lines and service valves. All outdoor unit and indoor coil connections are copper-to-copper and you must braze them with a phosphorous-copper alloy material such as Silfos-5 or equivalent. **Do not use soft solder.** VH4 outdoor units have reusable service valves on both the liquid and vapor connections. The total system refrigerant charge is retained within the outdoor unit during shipping and installation. The reusable service valves are provided to evacuate and charge as outlined in this manual. You can avoid serious service problems by taking adequate precautions to ensure an internally clean and dry system.

CAUTION

The indoor coil is under inert gas pressure. Relieve pressure from the coil by depressing the Schrader core at the end of the suction manifold stub out. Dry nitrogen must always be supplied through the tubing while it is being brazed because the temperature required is high enough to cause oxidation of the copper, unless an inert atmosphere is provided. The flow of dry nitrogen must continue until the joint cools. Always use a pressure regulator and safety valve to insure that only low pressure dry nitrogen is introduced into the tubing. Only a small flow is necessary to displace air and prevent oxidation.

CAUTION

Do not install any coil in a furnace which is to be operated during the heating season without attaching the refrigerant lines to the coil. The coil is under pressure which must be released to prevent excessive pressure build-up and possible coil damage.

CAUTION

Do not connect manifold gauges unless trouble is suspected. Approximately 3/4 oz of refrigerant is lost each time a standard manifold gauge is connected.

WARNING

Never attempt to repair any brazed connections while the system is under pressure. Personal injury could result.

Take the following precautions when brazing the service valves:

- Wrap a wet rag around the service valve to prevent heat damage, as shown in [Figure 17](#).
- Protect items such as painted surfaces and insulation during brazing.
- After brazing, cool the joint with a wet rag.

⚠ WARNING

This is not a backseating valve. The service access port has a valve core. Opening or closing the valve does not close the service access port. If the valve stem is backed out past the chamfered retaining wall, the O-ring can be damaged, causing leakage or system pressure that could force the valve stem out of the valve body, possibly causing personal injury.

Figure 17: Brazing the service valves

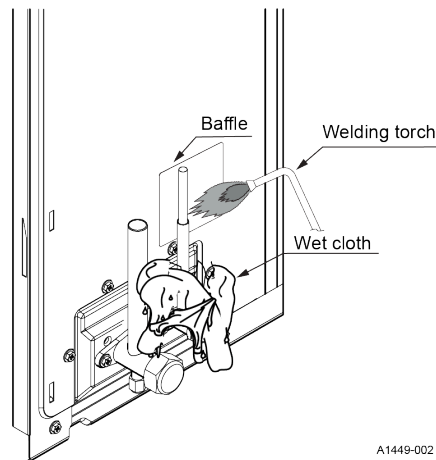

To braise the refrigerant lines and service valves, do the following:

1. Remove the cap and Schrader core from both the liquid and vapor service valve service ports at the outdoor unit.
2. Connect low pressure nitrogen to the liquid line service port.
3. Braze the liquid line to the liquid valve at the outdoor unit. Ensure to wrap the valve body with a wet rag. Allow the nitrogen to continue flowing.
4. Carefully remove the plugs from the liquid and vapor connections at the indoor coil.
5. Braze the liquid line to the indoor coil liquid connection. Nitrogen should be flowing through the indoor coil.
6. Slide the grommet away from the vapor connection at the indoor coil. Braze the vapor line to the indoor coil vapor connection. After the connection has cooled, slide the grommet back into its original position.
7. Protect the vapor valve with a wet rag and braze the vapor line connection to the outdoor unit. The nitrogen flow should be exiting the system from the vapor service port connection. After this connection has cooled, remove the nitrogen source from the liquid fitting service port.
8. Replace the Schrader core in the liquid and vapor valves.

Checking for refrigerant leaks

NOTICE

Pressurize the refrigerant piping and the indoor coil to 250 psig with dry nitrogen and leak test with a bubble type leak detector. Then release the nitrogen charge. Do not use the system refrigerant in the outdoor unit to purge or leak test.

To check for refrigerant leaks, do the following:

1. Pressurize the refrigerant piping and the indoor coil to 250 psig with dry nitrogen.
2. Leak test all refrigerant piping connections including the service port flare caps with a bubble type leak detector to ensure they are leak tight.
 - **Important:** Do not overtighten refrigerant piping connections: tighten between 40 in-lb and 60 in-lb.
3. Release the nitrogen charge.
4. If refrigerant leaks are present, repair the leaks and repeat Step 1 to Step 4 as needed until the testing indicates that no refrigerant leaks are present.

Required procedures for A2L systems

The following procedures are required for A2L systems:

Table 16: A2L required procedures

Procedure	A2L
Safely remove refrigerant, following local and national codes.	Required
Purge circuit with inert gas (oxygen-free nitrogen).	Required
Evacuate the refrigerant.	Required
Repair the system and purge with nitrogen during brazing.	Required
Leak test and pressure test the unit.	Required
Evacuate the system.	Required
Charge the system.	Required

Evacuating the refrigerant lines and indoor coil

You must test for refrigerant leaks using dry nitrogen as outlined in [Checking for refrigerant leaks](#) before evacuating the refrigerant lines and indoor coil. Evacuating the system involves taking a micron gauge reading, which can also help indicate if there are any refrigerant leaks.

NOTICE

If a leak is suspected, leak test with dry nitrogen to locate the leak. Repair the leak and test again. To verify that the system has no leaks, close the valve to the vacuum pump suction to isolate the pump and hold the system under vacuum. Watch the micron gauge for a few minutes. If the micron gauge indicates a steady and continuous rise, it is an indication of a leak. If the gauge shows a rise, then levels off after a few minutes and remains fairly constant, it is an indication that the system is leak free but still contains moisture and may require further evacuation if the reading is above 500 microns.

To evacuate the refrigerant lines and indoor coil, do the following:

1. Evacuate the vapor line, indoor coil, and liquid line to 500 microns or less.
2. To verify that the system has no refrigerant leaks, close the valve to the vacuum pump suction to isolate the pump and hold the system under vacuum. Watch the micron gauge for a few minutes and take further action if needed as outlined in [Table 17](#).

Table 17: Understanding the micron gauge reading

Micron gauge reading	Approach
The micron gauge shows a steady and continuous rise. This indicates that there is a refrigerant leak.	Follow the procedure in Checking for refrigerant leaks to leak test with dry nitrogen to locate the refrigerant leak. When you have repaired the refrigerant leak, do another micron gauge reading to make sure that there is no indication of a refrigerant leak.
The micron gauge shows a rise, then levels off after a few minutes and remains fairly constant. This indicates that there are no refrigerant leaks but the system still contains moisture and may require further evacuation.	If the micron gauge reading is above 500 microns, evacuate the vapor line, indoor coil, and liquid line again to 500 microns or less.

Releasing the refrigerant into the system

Make sure that you have checked the refrigerant system for leaks and evacuated the refrigerant lines and indoor coil before releasing the factory refrigerant charge into the system. See [Checking for refrigerant leaks](#) and [Evacuating the refrigerant lines and indoor coil](#).

To release the refrigerant into the system, you must open the liquid line service valve first, and then open the vapor line service valve.

CAUTION

Do not connect manifold gauges unless required to mitigate an identified issue. Approximately 3/4 oz of refrigerant is lost each time a standard manifold gauge is connected.

⚠ WARNING

Never attempt to repair any brazed connections while the system is under pressure. Personal injury could result.

To release the refrigerant into the system, do the following:

1. Open the liquid line service valve by removing the plunger cap and back out the valve stem counterclockwise using a hex head wrench until fully open. Allow the refrigerant pressure to completely equalize, and then open the vapor line service valve in the same way.
If the service valve is a ball type valve, use an adjustable end wrench to turn the valve 1/4 turn to open.
2. Replace the caps on the service ports. Do not remove the flare caps from the service ports except when necessary for servicing the system.
3. Replace the plunger caps finger tight, then tighten an additional 1/12 turn (1/2 hex flat). Ensure to replace the caps to prevent leaks.

4. Figure 18: Service port and valve cap

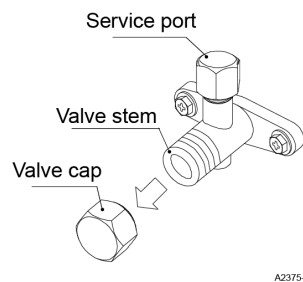

Table 18: Tightening torque of each screw

Pipe size [in. (mm)]	For valve cap [lbf-ft. (N·m)]	For service port [lbf-ft. (N·m)]
∅ 1/4 (6.35)	14.8~18.4(20~25)	7.4±0.7 (10±1)
∅ 3/8 (9.52)	14.8~18.4(20~25)	
∅ 1/2 (12.70)	18.4~22.1(25~30)	
∅ 5/8 (15.88)	22.1~25.8(30~35)	
∅ 3/4 (19.05)	29.5~33.2(40~45)	

Adjusting refrigerant charge

VH4 outdoor units are precharged with enough R-454B refrigerant for the outdoor unit, the smallest indoor unit, and 25 ft of refrigerant piping. If the refrigerant piping is longer than 25 ft, you must add additional refrigerant. See [Table 8](#) for more information. Refer to the *Tabular Data Sheet* for more information on precharge amount and indoor combinations.

CAUTION

Refrigerant charging must only be carried out by a licensed qualified air conditioning contractor.

CAUTION

Compressor damage occurs if the system is incorrectly charged. On new system installations, charge the system as instructed in the *Tabular Data Sheet* for the matched coil and follow the guidelines in this instruction.

CAUTION

Do not leave the system open to the atmosphere. Unit damage could occur due to moisture being absorbed by the POE oil in the system. This type of oil is highly susceptible to moisture absorption.

CAUTION

It is unlawful to knowingly vent, release, or discharge refrigerant into the open air during repair, service, maintenance, or the final disposal of this unit.

To adjust the refrigerant charge, follow the charging procedure in the *Tabular Data Sheet* for the outdoor unit.

Connecting the wiring

To connect the wiring correctly, you must do the following:

1. Complete the field wiring connections.
 2. Carry out all necessary electrical checks.
- See [Wiring diagrams](#) for the outdoor unit wiring diagrams.

Completing the field wiring connections

Make sure that all field wiring is in accordance with the National Electrical Code (NEC) and local city codes. The VH4 outdoor unit works as part of a conventional system and uses conventional 24 V thermostat wiring.

⚠ CAUTION

This equipment uses an inverter drive that stores hazardous energy up to 5 min after power is removed. Wait for more than 5 min before performing electrical work after power is removed.

NOTICE

Local codes may require use of an ELB (Earth Leakage Breaker) or RCD (Residual Current Device) breaker. When required, use a breaker capable of handling harmonics to prevent failure of the ELB or RCD breaker.

After the installation of the machine is completed, the service port cap and the valve cap need to be installed, see [Figure 18](#) and [Table 18](#).

Table 19: Physical and electrical data

Model	VH412E2S11	VH418E2S11	VH424E2S11	VH430E2S11	VH436E2S11	VH442E2S11	VH448E2S11	VH460E2S11	
Unit supply voltage	208-230 V, 1 phase, 60 Hz								
Normal voltage range ¹	187 V to 253 V								
Minimum circuit ampacity	12	16	20	21	21	31	39	39	
Maximum overcurrent device amps ²	20	25	25	30	30	40	50	50	
Compressor	Type	Twin rotary	Twin rotary	Twin rotary	Twin rotary	Twin rotary	Twin rotary	Twin rotary	Twin rotary
	Maximum load amps	9	12	14	15	15	23	29	29
Crankcase heater	Yes	Yes	Yes	Yes	Yes	Yes	Yes	Yes	
Basepan heater	Yes	Yes	Yes	Yes	Yes	Yes	Yes	Yes	
Fan diameter (in.)	19.53	19.53	19.53	21.89	21.89	24.40	24.40	24.40	
Fan motor	Type	DC	DC	DC	DC	DC	DC	DC	
	Rated HP	1/12	1/12	1/12	1/7	1/7	1/3	1/3	
	RLA (amp)	0.5	0.5	0.5	0.8	0.8	1.98	2.7	
	Nominal RPM	880/500	880/700	880/650	870/500	880/500	850/500	850/500	
	Nominal CFM (Hi/Low)	1950/800	1850/1300	1850/1150	2235/1300	2235/1300	3350/2295	3350/2295	
Coil	Face area sq. ft.	6.10	6.10	6.10	7.45	7.45	10.76	10.76	
	Rows deep	1	2	2	2	2	2	2	
	Fins/Inch	18	18	18	18	18	18	18	
Liquid refrigerant piping outdoor (field installed)	3/8	3/8	3/8	3/8	3/8	3/8	3/8	3/8	
Vapor refrigerant piping outdoor (field installed)	5/8	5/8	5/8	5/8	5/8	7/8	7/8	7/8	
Unit charge (lb - oz) 25 ft	3	3 - 5	4 - 1	4 - 10	5 - 2	7 - 6	7 - 12	8 - 15	
Charge per ft, oz	0.38	0.38	0.38	0.38	0.38	0.38	0.38	0.38	
Net weight lbs	91.5	98.1	98.1	113.5	113.5	186.7	186.7	187.4	

① Note:

1. Rated in accordance with AHRI Standard 110-2016, utilization range A.
2. Dual element fuses or HACR circuit breaker. Maximum allowable overcurrent protection.

To complete the field wiring connections, do the following:

1. Install the correct size weatherproof disconnect switch outdoors and within sight of the outdoor unit according to local codes.
2. Run the power wiring from the disconnect switch through the power wiring exit provided and to the outdoor unit.
3. Connect the power wiring from the disconnect switch into the outdoor unit control box as outlined for the specific outdoor unit model in [Table 20](#).

Table 20: Connecting the power wiring from the disconnect switch into the outdoor unit control box

Outdoor unit model	Approach	Illustration
VH412E2S11	<ol style="list-style-type: none"> 1. Unscrew the mounting screws to remove the electric box cover. 2. Fasten the power supply cable and the low-voltage cable to the conduit holder using the lock nut. 3. Connect the power supply cable and the low-voltage cable to the terminal. 	Figure 19
VH418E2S11		
VH424E2S11		
VH430E2S11		
VH436E2S11	<ol style="list-style-type: none"> 4. Make sure to seal any holes when the wiring is complete. Place the cables side to side. Do not overlap the cables. 5. Re-install the electric box cover when the wiring is complete. 	Figure 20 Figure 21 Figure 22
VH442E2S11		
VH448E2S11		
VH460E2S11		

Figure 19: Connecting the power wiring from the disconnect switch into the control box for VH412E2S11, VH418E2S11, VH424E2S11, VH430E2S11 and VH436E2S11 units

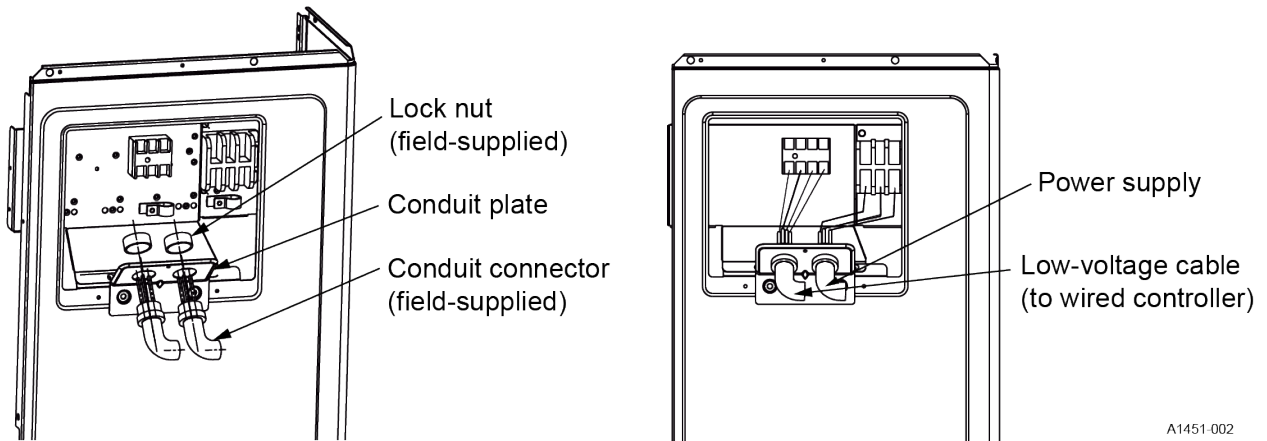

A1451-002

Figure 20: Connecting the power wiring from the disconnect switch into the control box for VH442E2S11, VH448E2S11, and VH460E2S11 - illustration 1

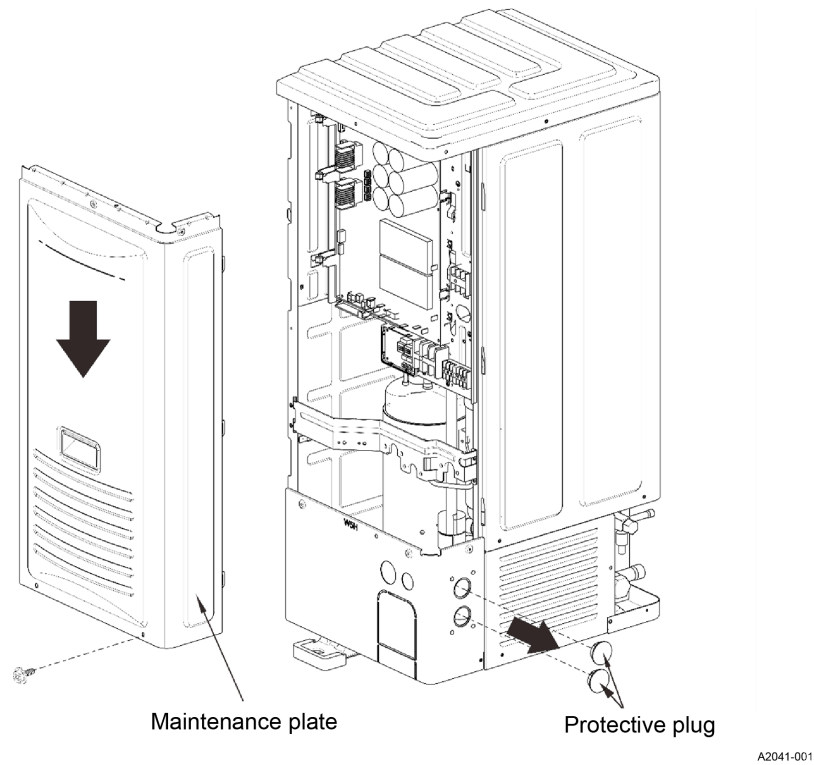

Figure 21: Connecting the power wiring from the disconnect switch into the control box for VH442E2S11, VH448E2S11, and VH460E2S11 - illustration 2

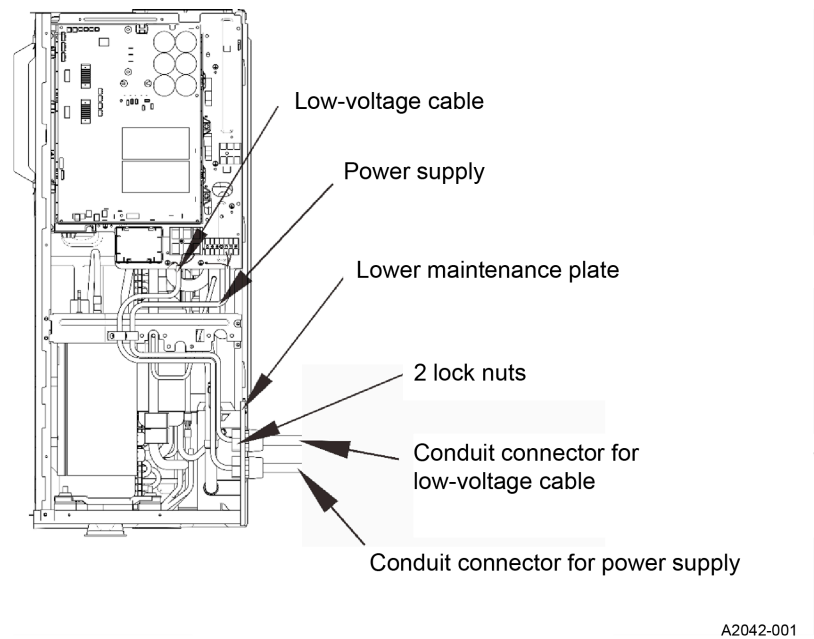
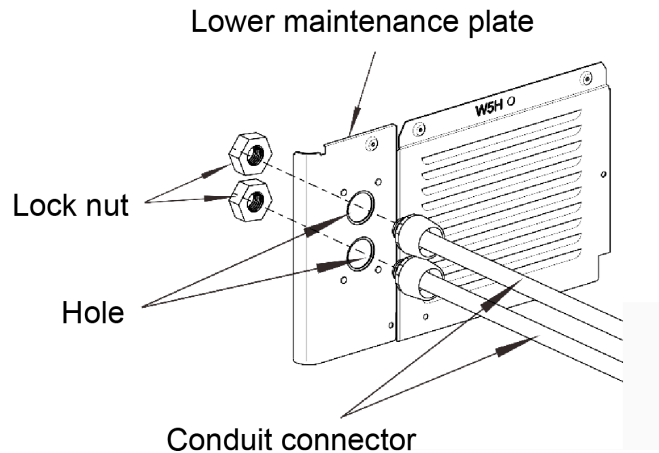

Figure 22: Connecting the power wiring from the disconnect switch into the control box for VH442E2S11, VH448E2S11, and VH460E2S11 - illustration 3



A2043-001

6. Make the power supply connections to the supplied terminal block. See [Figure 23](#).

NOTICE

When connecting to the terminal block using a stranded wire, make sure to use the round crimp-style solderless terminal. If using solid wire, do not use a solderless connector.

Figure 23: Connecting the power supply

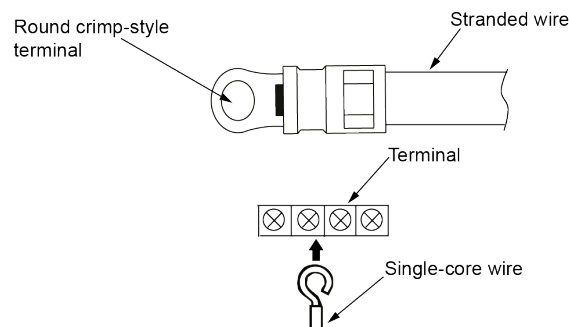

A1455-002

7. Mount the thermostat 5 ft above the floor, where it is exposed to normal room air circulation.
 - **Important:** You must not place the thermostat on an outside wall or where it is exposed to the radiant effect from exposed glass or appliances, drafts from outside doors, or supply air grilles.
8. Route the 24 V control wiring from the outdoor unit to the indoor unit and the thermostat. Keep the low-voltage wiring 4 in. or more away from the high-voltage wires that are leaving the control box.
 - **Important:** The 24 V control wiring must be NEC Class 2.
9. Wrap tape along the wire and seal any wiring holes to prevent entry of condensate water and insects.

Control wiring diagrams

The VH4 model heat pump requires a multi-stage room thermostat.

Figure 24: Control wiring - JWE and Generation 2 JHE standard ECM air handler and VH4 heat pump - conventional wiring

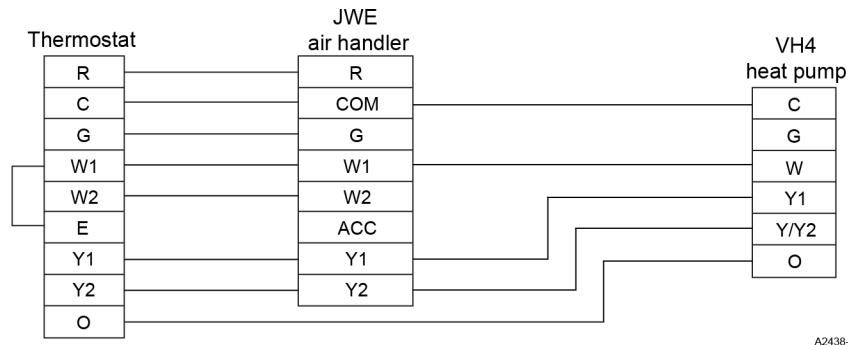

NOTICE

JWE and JHE ACC wire connection will be powered (24V) any time the unit refrigerant detection system is in an alarm state.

Figure 25: Control wiring - VHE standard ECM air handler and VH4 heat pump - conventional wiring

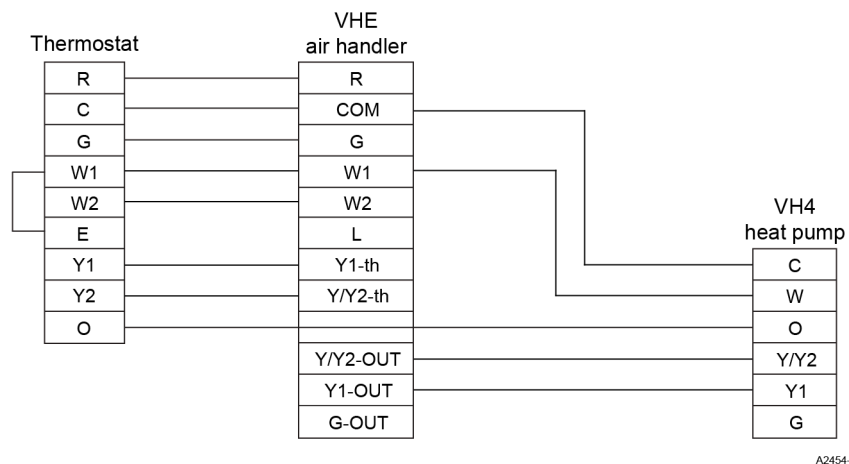

Table 21: Wire and connection key

Wire	Connection
L	Malfunction light (optional)
Y1	Low stage compressor
Y/Y2	High stage compressor
Y1-th	Cool 1 / Heat 1 from thermostat
Y1-OUT	Cool 1 / Heat 1 for outdoor unit
Y/Y2-th	Cool 2 / Heat 2 from thermostat
Y/Y2-OUT	Cool 2 / Heat 2 for outdoor unit
O	Reversing valve input
C	24 V common
R	AC 24 V power supply
G	24 V input signal from thermostat
W	Defrost signal
W1/W2	Electric auxiliary heat input

Low-voltage wire connections for VH4 heat pump

Table 22: Low-voltage wire connections

Wire	Connection
C	24 V common
G	24 V input signal
O	Reversing valve input
Y1	Low stage compressor
Y/Y2	High stage compressor
W	Auxiliary heat output (not always used)

Performing electrical checks

When you have finished connecting and securing all wiring, perform all required electrical checks.

To perform electrical checks, do the following:

- Ensure that the field-selected electrical components including main power switches, circuit breakers, wires, conduit connectors, and wire terminals have been correctly selected according to the electrical data in [Table 19](#). Ensure that the components comply with the NEC.
- Ensure the voltage of the power supply is within 10% of nominal voltage and the ground is contained in the power supply wires. If not, electrical parts may be damaged.
- Ensure that the capacity of the power supply is of sufficient size. If not, an abnormal voltage drop when starting the outdoor unit may prevent the compressor from operating.
- Ensure that the ground wire is connected.
- Ensure that the electrical resistance is more than 2 MΩ, by measuring the resistance between the ground and the terminal of the electrical parts. If the electrical resistance is not more than 2 MΩ, do not operate the system until the electrical leakage is found and repaired.

Starting up the system

When the outdoor unit is in place and the refrigerant piping and wiring are complete, you must start up the system and make sure that the system is operating correctly.

CAUTION

Do not operate the system until all the checks outlined in this procedure have been performed.

CAUTION

The outdoor unit is provided with a compressor and base heater. Check to ensure the main power has been on for more than 6 h ahead of unit operation to avoid damage to the compressor.

WARNING

Do not touch any of the parts at the discharge gas side by hand. The compressor chamber and the pipes at the discharge side are heated to temperatures higher than 194°F (90°C).

To start up the system, do the following:

1. Check to ensure that the service base valves of the outdoor unit are fully open.
2. Check to ensure that the electric wires are fully connected.
3. Use the thermostat to turn on the system.
4. Make sure that the system is operating correctly.

 **Note:** See [System components and operation](#) for more information about the system if needed. If any troubleshooting is required, see [Troubleshooting](#) for guidance.

Adjusting system settings

You may need to adjust the system settings after installation or for servicing. You do this using the DIP switches in the S4 switch bank or the S5 switch bank. These are the options:

- Alternate temperature and pressure mode
See [Activating alternate temperature and pressure mode for all VH4 outdoor models](#).
- Pump down mode
See [Activating pump down mode for all VH4 outdoor models](#).
- Forced defrost mode
See [Activating forced defrost mode for all VH4 outdoor models](#).

The line voltage power must be ON when you are setting the DIP switches S4-2 or S4-3 for all VH4 outdoor models.

The line voltage power must be OFF when you are setting DIP switches S4-1, S5-1, and S5-2 for all VH4 outdoor models.

The factory setting, or address, of the DIP switches in the S4 and S5 switch banks is 0000 or OFF/OFF/OFF/OFF. In [Figure 26](#), ■ indicates the position of each switch for factory settings, pump down mode, forced defrost mode, and lower capacity mode.

Figure 26: DIP switch settings for all VH4 outdoor units

S5 SWITCH BANK		S4 SWITCH BANK	
Factory setting		Factory setting	
Capacity Hi — Low		Temperature pressure - imperial	
		Pump down switch	
		Forced defrost	

A2520-001

ⓘ Note:

1. Turn ON the power before setting the S4-2 or S4-3 DIP switches, and dial the switches from OFF to ON. Without having the unit powered ON, the switch settings are not refreshed and might be invalid.
2. Turn OFF all power sources before setting the S4-1, S5-1, or S5-2 DIP switches. Without having the unit powered OFF, the switch settings are not refreshed and might be invalid.
3. The icon ■ indicates the position of the DIP switches.

Temperature and Pressure unit: On S4-1 the control board will show temperature and pressure in degrees celsius and Mpa. When in the OFF or DOWN position, it will display metric units, and when it moves to the UP or ON position, it will display imperial units, degrees fahrenheit and psig.

Activating alternate temperature and pressure mode for all VH4 outdoor models

The unit's 7-segment display is factory set for the metric system, therefore temperature is displayed in Celsius and pressure is displayed in MegaPascals / MPa.

To change the display to the imperial system, complete the following steps:

1. Disconnect line voltage power from the unit and wait for the display to go blank.
2. Change dip-switch 1 in the S4 switch bank from OFF to ON and restore power.

The temperature will now be displayed in Fahrenheit and the pressure will now be displayed in pounds per square inch / PSI.

Activating pump down mode for all VH4 outdoor models

You must activate pump down mode for refrigerant recovery. When the outdoor unit is in pump down mode, the compressor runs with a target frequency and without any protection when the frequency rises. The electronic expansion valve (EEV) runs with an open setting. The outdoor unit fan runs with the set fan speed.

NOTICE

The refrigerant in systems with refrigerant piping in excess of 40 ft cannot be recovered into the outdoor unit and requires recovery with external equipment.

- **Important:** The line voltage power must be ON when you are setting the DIP switch to activate pump down mode.
- ⓘ **Note:** Make sure to change the DIP switch setting to take the outdoor unit out of pump down mode after the refrigerant recovery operation. If not, the outdoor unit enters pump down mode again after powering on.

To activate pump down mode for all VH4 outdoor models, do the following:

1. Remove the heating or cooling call from the outdoor unit so it is in standby mode.
2. Close the liquid line service valve using a hex head wrench by turning the valve stem fully clockwise until seated as shown in [Figure 27](#).

Figure 27: Unit service valves for VH412E2S11, VH418E2S11, VH424E2S11, VH430E2S11, and VH436E2S11 models

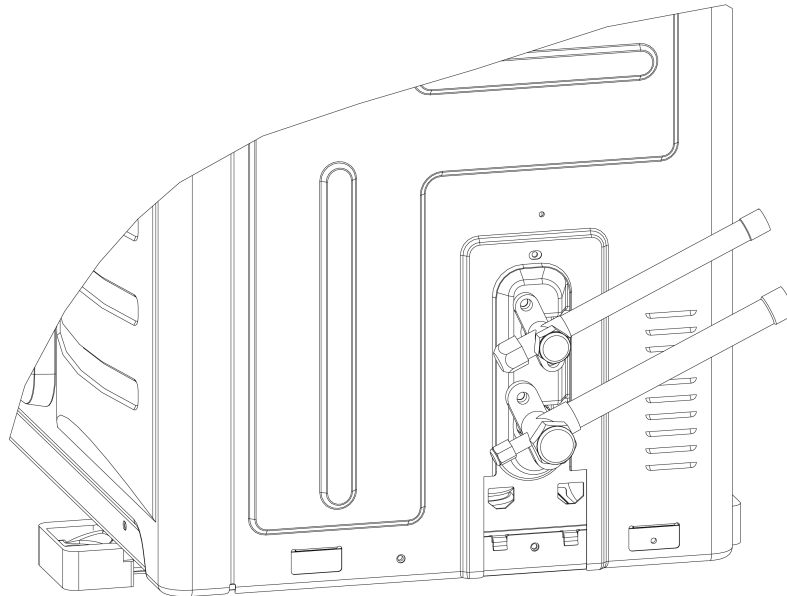

A2270-002

Figure 28: Unit service valves for VH442E2S11, VH448E2S11, and VH460E2S11 models

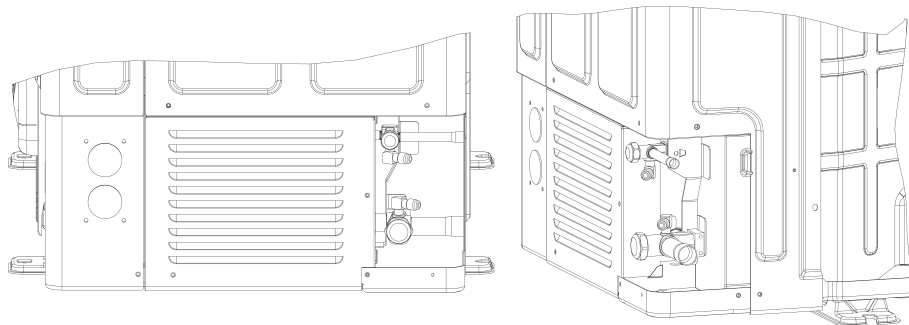

A2271-002

3. Open the maintenance panel.
4. With the line voltage power applied to the outdoor unit, place the outdoor unit in pump down mode by setting the DIP switch on the S4 switch bank on the 7-segment display control board as shown for pump down mode in [Figure 26](#).
5. Wait for the 7-segment display on the 7-segment display control board to display **CLOS**. When the 7-segment display shows **CLOS**, wait as the outdoor unit continues to run.
 - ⓘ **Note:** Be aware that the 7-segment display starts to display the compressor frequency value before it displays **CLOS**.
6. When the 7-segment display shows **GOOD**, close the vapor line service valve using a hex head wrench by turning the valve stem fully clockwise until seated as shown in [Figure 27](#).
7. Take the outdoor unit out of pump down mode by setting the DIP switches on the S4 switch bank on the 7-segment display control board to the off position and immediately remove the line voltage power from the outdoor unit.

Activating forced defrost mode for all VH4 outdoor models

The VH4 outdoor unit controls have a built-in feature to activate forced defrost mode if required.

- **Important:** The line voltage power must be on when you are setting the DIP switch to activate forced defrost mode.

To activate forced defrost mode for all VH4 outdoor models, do the following:

1. Open the maintenance panel.
2. Place the outdoor unit in forced defrost mode by setting the DIP switch on the S4 switch bank on the main control board as shown for forced defrost mode in [Figure 26](#).
3. The outdoor unit operates in forced defrost mode.
4. Take the outdoor unit out of forced defrost mode by setting the DIP switch on the S4 switch bank on the main control board to the off position.

Checking outdoor unit parameters

You can run a parameter query to view various outdoor unit parameters during installation or for servicing. This allows you to check the running status of the outdoor unit and view active outdoor unit fault codes and protection codes, for example. See [Viewing fault codes and protection codes for all VH4 outdoor models](#) for more information about viewing different types of fault codes.

For VH4 outdoor units, you run parameter queries using the 7-segment display components on the 7-segment display control board. See [Running a parameter query for all VH4 outdoor models](#).

[Figure](#) shows the 7 segment display components for VH4 outdoor units. [Figure 29](#) shows how to use the S1, S2, and S3 buttons for the 7-segment display.

Figure 29: Using the buttons for the 7-segment display

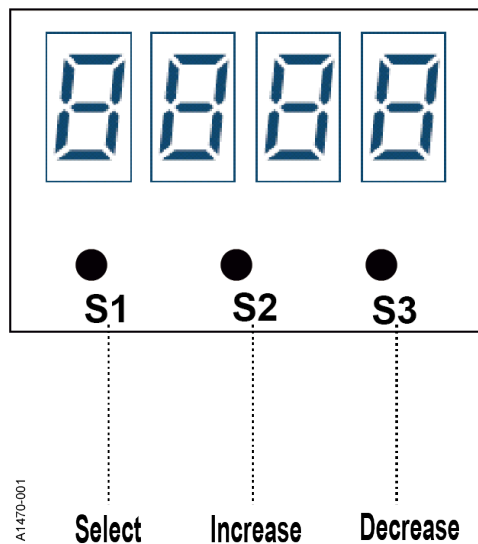

Running a parameter query for all VH4 outdoor models

For VH4 outdoor units, you run parameter queries using the 7-segment display components on the 7-segment display control board. See [Checking outdoor unit parameters](#) and [Viewing fault codes and protection codes for all VH4 outdoor models](#) for more information.

Table 23: Parameter codes for all VH4 outdoor models

Parameter code	Description
P.0	Fault codes
P.1	Compressor actual frequency
P.2	Compressor driving frequency
P.4	Compressor target frequency
P.5	Compressor discharge temperature
P.6	Outdoor suction temperature
P.7	Outdoor ambient temperature
P.8	Outdoor coil temperature
P.9	Outdoor defrosting temperature
P.10	IPM module temperature
P.11	Outdoor capacity requirement
P.12	IPM fault codes
P.13	Outdoor DC motor target speed
P.14	AC input current
P.15	AC input voltage
P.16	DC bus voltage
P.17	Compressor phase current
P.18	Frequency limit code
P.20	Target suction overheating
P.21	Target discharge overheating
P.22	Actual suction overheating, heating
P.23	Actual discharge overheating, heating
P.24	Actual outdoor pressure

Note: The right is reserved for the EE to change without notice.

To run a parameter query for all VH4 outdoor models, do the following:

- Press the **S1** button to display the outdoor unit parameter.
P. indicates the parameter of the outdoor unit. For example, **P.0** is the parameter code for outdoor unit fault codes or protection codes, and **P.1** is the parameter code for compressor actual frequency.
- Use the **S2** and **S3** buttons to increase and decrease the parameter number as needed to display the parameter code of the parameter you want to view, for example, **P.14** for AC input current.
 Press **S2** to increase the parameter number by one or press and hold **S2** to increase the parameter number rapidly. Press **S3** to decrease the parameter number by one or press and hold **S3** to decrease the parameter number rapidly. See [Figure 29](#) and [Table 23](#).
- Wait for 3 s. The parameter content is automatically displayed.
Note: When the parameter content displays for the **P.0** parameter code, **E** displays with the outdoor unit fault code or protection code, for example, **E 13**. If there are multiple outdoor unit fault codes or protection codes, the codes display in sequence.

System components and operation

It is important to be familiar with the different system components and understand how they operate.

Refrigerant cycle

The following figures illustrate the refrigerant flow in heating mode and cooling mode and the refrigerant cycle components for VH4 outdoor units.

Figure 30: Refrigerant cycle components for VH412E2S11, VH418E2S11 and VH424E2S11 units

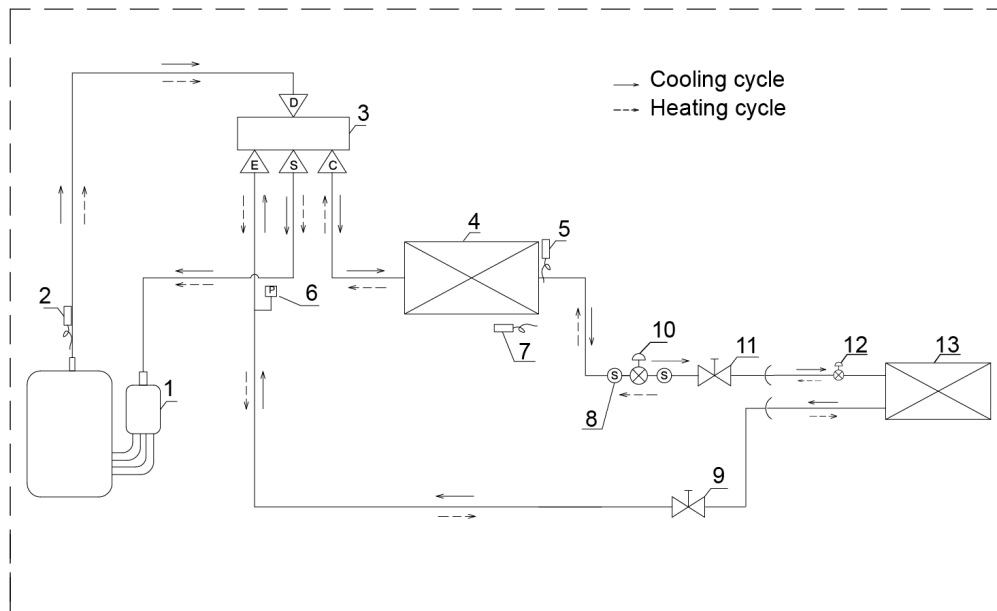

A2417-001

Table 24: List of components for VH412E2S11, VH418E2S11 and VH424E2S11 units

Number	Description	Number	Description
1	Compressor	8	Strainer
2	Discharge temperature sensor	9	Stop valve - gas
3	Four-way valve	10	Electronic expansion valve
4	Outdoor heat exchanger	11	Stop valve - liquid
5	Coil temperature sensor	12	TXV
6	Pressure sensor	13	Indoor heat exchanger
7	Ambient temperature sensor		

Figure 31: Refrigerant cycle components for VH430E2S11 and VH436E2S11 units

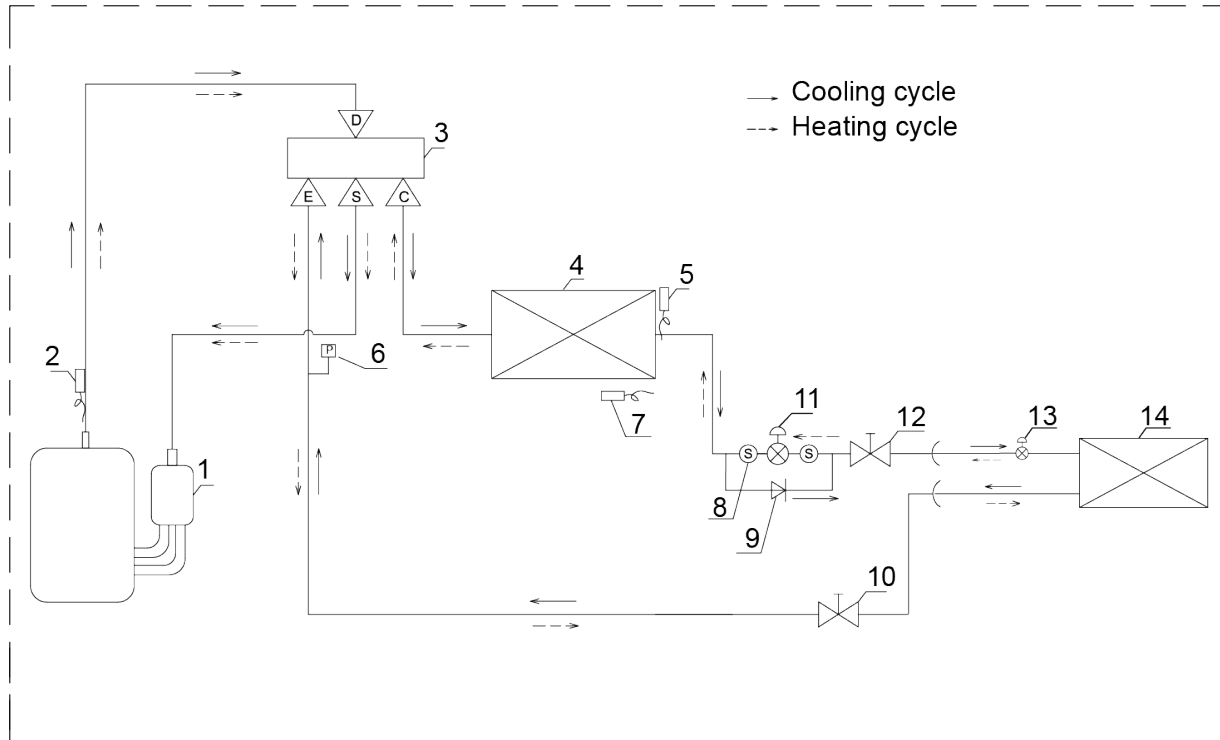

A2045-001

Table 25: List of components for VH430E2S11 and VH436E2S11 units

Number	Description	Number	Description
1	Compressor	8	Strainer
2	Discharge temperature sensor	9	One-way valve
3	Four-way valve	10	Stop valve - gas
4	Outdoor heat exchanger	11	Electronic expansion valve
5	Coil temperature sensor	12	Stop valve - liquid
6	Pressure sensor	13	TXV
7	Ambient temperature sensor	14	Indoor heat exchanger

Figure 32: Refrigerant cycle components for VH442E2S11, VH448E2S11, and VH460E2S11 units

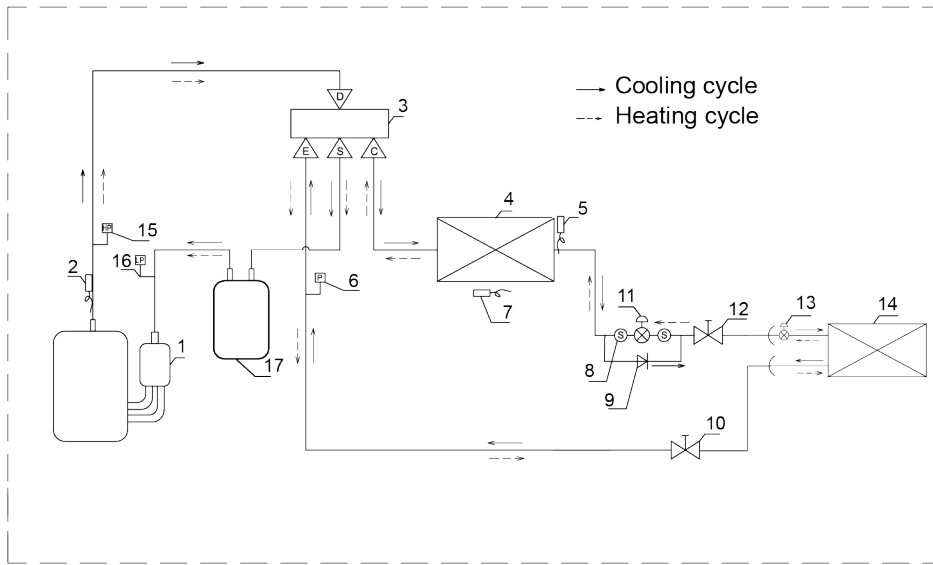

A2046-002

Table 26: List of components for VH442E2S11, VH448E2S11, and VH460E2S11 units

Number	Description	Number	Description
1	Compressor	10	Stop valve - gas
2	Discharge temperature sensor	11	Electronic expansion valve
3	Four-way valve	12	Stop valve - liquid
4	Outdoor heat exchanger	13	TXV
5	Coil temperature sensor	14	Indoor heat exchanger
6	Pressure sensor	15	High-pressure switch
7	Ambient temperature sensor	16	Low-pressure switch
8	Strainer	17	Gas-liquid separator
9	One-way valve		

Control boards for VH412E2S11, VH418E2S11, VH424E2S11, VH430E2S11, and VH436E2S11 units

VH418E2S11, VH424E2S11, and VH430E2S11 outdoor units include a main control board with an integrated drive board.

Figure 33: Main control board for VH412E2S11, VH418E2S11, VH424E2S11, VH430E2S11, and VH436E2S11 units

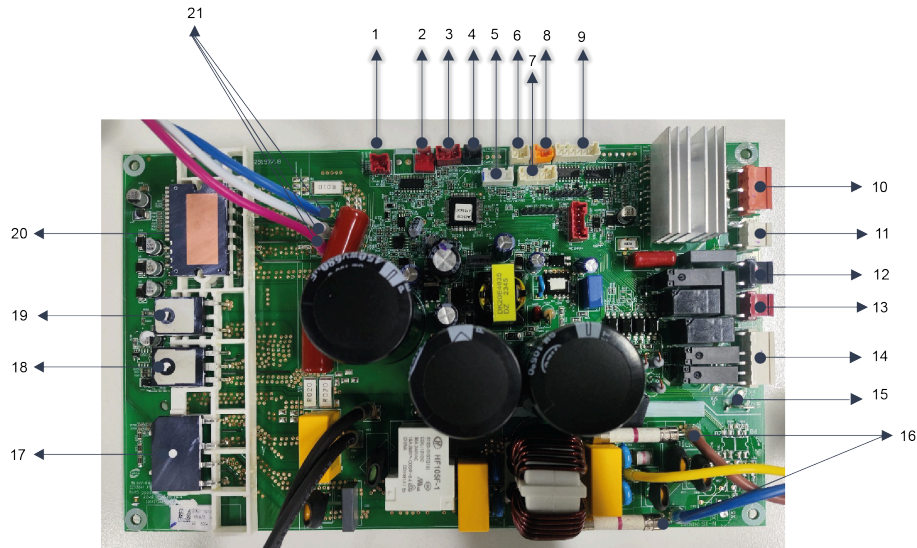

A2033-002

Table 27: List of components

Number	Description	Number	Description
1	Overheat protection switch	12	Four-way valve
2	High pressure switch	13	Base heater
3	Pressure sensor	14	24V communication signal C/G/O/Y1/Y2
4	Coil temperature sensor	15	24V communication signal W
5	Program	16	AC IN - L and AC IN - N
6	Discharge temperature sensor	17	Rectifier
7	Checker/black box	18	IGBT
8	Ambient temperature sensor	19	Diode
9	Electronic expansion valve (EEV)	20	IPM
10	DC fan motor	21	Compressor wires
11	Electric heating belt		

Control boards for VH442E2S11, VH448E2S11, and VH460E2S11 units

VH442E2S11, VH448E2S11, and VH460E2S11 outdoor units include a main control board with a filter board/drive board.

Figure 34: Main control board for VH442E2S11, VH448E2S11, and VH460E2S11 units

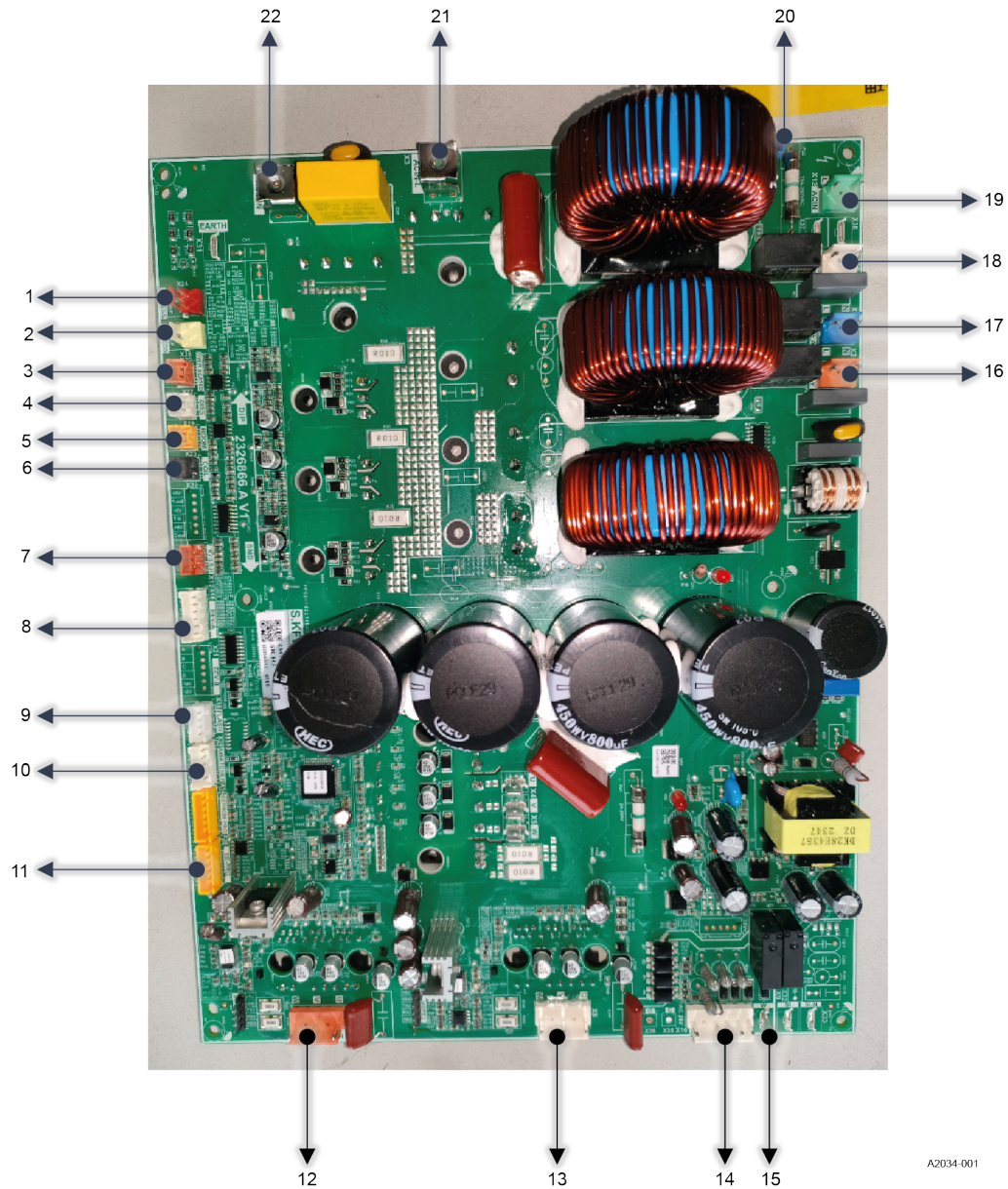

A2034-001

Table 28: List of components

Number	Description	Number	Description
1	High pressure switch	12	DC fan motor 2
2	Low pressure switch	13	DC fan motor 1
3	Overheat protection switch	14	24V communication signal - C/G/O/Y1/Y2
4	Discharge temperature sensor	15	24V communication signal - W
5	Ambient temperature sensor	16	Four-way valve
6	Coil temperature sensor	17	Base heater
7	Pressure sensor	18	Electric heating belt
8	Electronic expansion valve (EEV)	19	AC IN-LN
9	Program	20	PTC signal
10	Checker/black box	21	AC IN - L
11	EE-prog	22	AC IN - N

Figure 35: Filter board/drive board for VH442E2S11/VH448E2S11/VH460E2S11 units

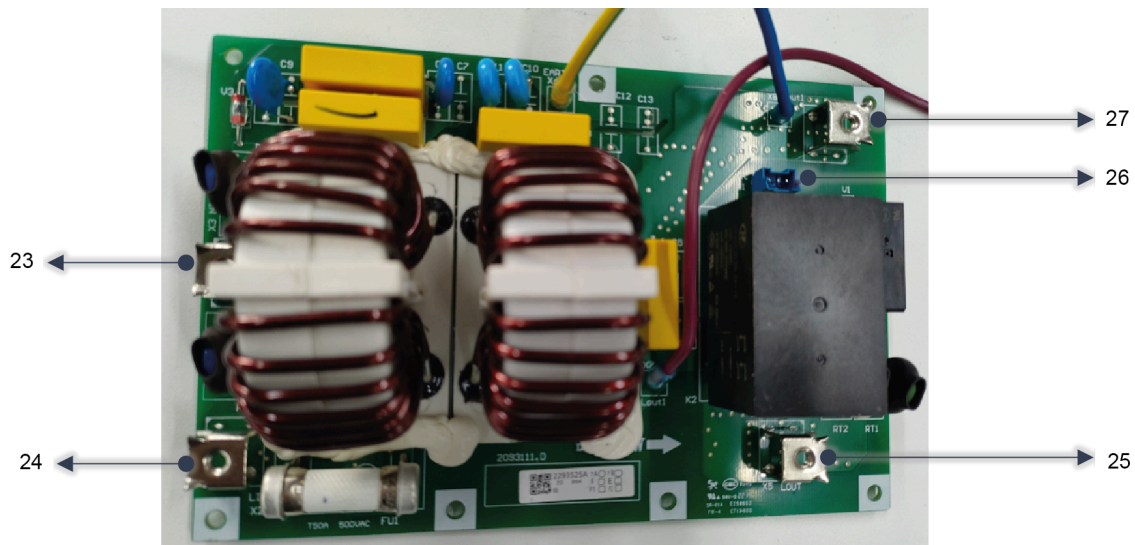

A2035-001

Table 29: List of components

Number	Description	Number	Description
23	AC IN - N	26	PTC signal
24	AC IN - L	27	AC OUT - N
25	AC OUT - L		

Figure 36: 7-segment display control board for all VH4 units

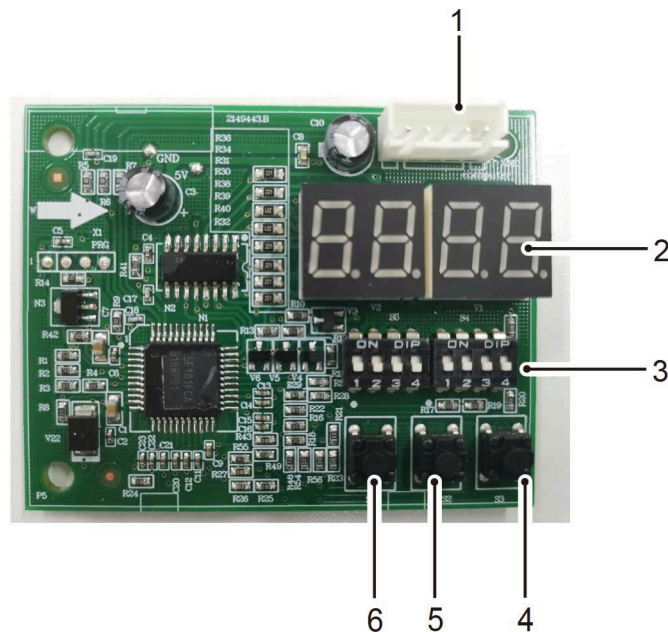

A1463-003

Table 30: List of components

Number	Description	Number	Description
1	Computer/Checker to outdoor control board	4	S3 button - decrease
2	7-segment display	5	S2 button - increase
3	DIP switch	6	S1 button - select

Heating and cooling operation and safety components

VH4 outdoor units include the following heating and cooling operation and safety components:

- **Cooling anti-freeze protection:** The outdoor pressure sensors monitor evaporator pressure and saturated temperature. This feature prevents the indoor unit evaporator temperature from becoming too low. If the indoor coil temperature is too low, the compressor automatically engages protection mode.
- **Overload protection:** To prevent system overload caused by excessive pressure, the control implements real-time detection when the outdoor coil temperature is too high during cooling mode or the indoor coil temperature is too high during heating mode.
- **Compressor discharge temperature protection:** To prevent damage due to a high compressor discharge temperature, the control monitors the discharge gas temperature and provides automatic protection if the temperature is too high.
- **Oil-return control:** When the compressor runs at low frequencies for a long time, the control initiates an oil-return sequence to ensure that oil is returned to the compressor.
- **Heating and cooling operation:** Users set the thermostat to activate heating or cooling mode.
- **Four-way valve control:** The four-way valve of the outdoor unit is de-energized in cooling and defrosting, and energized in heating. During heating, the four-way valve is de-energized for a period of time after the compressor stops.

- **Start-up protection:** To prevent frequent compressor starts where the system pressure has not equalized, the control invokes a delay of 3 min between cycles to prevent short cycles.
- **Pressure protection:** When the pressure increases to a preset value, the pressure switch automatically changes to protection mode. The compressor stops and reports the protection code.

Sensor parameters

You can use the sensor parameters to verify sensor resistance if the outdoor unit sensors malfunction or fail.

These are the parameters for the outdoor compressor discharge sensor:

(R0=187.25K±6.3%, R100=3.77K±2.5K, B0/100=3979K±1%)

Table 31: Outdoor compressor discharge temperature sensor

T [°C]	Rmin [kΩ]	Rnom [kΩ]	Rmax [kΩ]	Dev(MIN)%	Dev(MAX)%
-30	908.2603	985.5274	1065.1210	-7.84	7.47
-15	384.2888	413.3808	442.9105	-7.04	6.67
0	175.4533	187.2500	199.0468	-6.30	5.93
15	85.4114	90.4842	95.5398	-5.61	5.29
30	44.1034	46.4046	48.6960	-4.96	4.71
45	23.9697	25.0632	26.1488	-4.36	4.15
60	13.6400	14.1799	14.7154	-3.81	3.64
75	8.0951	8.3705	8.6440	-3.29	3.16
90	4.9853	5.1292	5.2726	-2.81	2.72
105	3.1632	3.2491	3.3353	-2.64	2.58

These are the parameters for the suction, ambient, coil, and discharge sensors:

(R0=15k±2%, B0/100=3450k±2%)

Table 32: Outdoor ambient and coil temperature sensor

T [°C]	Rmin [kΩ]	Rnom [kΩ]	Rmax [kΩ]	Dev(MIN)%	Dev(MAX)%
-30	60.78	64.77	68.99	-6.16	6.12
-15	29.07	29.97	30.89	-3.00	2.98
0	14.70	15.00	15.29	-2.00	1.90
15	7.804	8.021	8.240	-2.71	2.66
30	4.355	4.550	4.753	-4.29	4.27
45	2.558	2.701	2.850	-5.29	5.23
60	1.551	1.654	1.762	-6.23	6.13
75	0.9676	1.041	1.120	-7.05	7.05
90	0.6188	0.6718	0.7291	-7.89	7.86
105	0.4056	0.4440	0.4859	-8.65	8.62

Troubleshooting

Variable capacity systems can be difficult to troubleshoot given integrated fault isolation and protection algorithms. When the system is not operating within acceptable parameters or you need to verify system or component operation, it may be necessary to perform specific system checks. To isolate potential root causes, do the following:

1. Complete an initial check of the refrigerant system components. See [Checking refrigerant system components](#).
2. Use the cooling mode and heating mode flow charts to check for issues and determine if the outdoor unit is operating as designed. See [Checking cooling and heating operation](#).
3. Follow the troubleshooting guidance for specific issues as needed. See , [Outdoor unit faults and protection](#), [Drive faults](#), [Overload in cooling mode](#), and [Overload in heating mode](#).

Checking refrigerant system components

If troubleshooting is required after installation, complete this initial check of refrigerant system components before proceeding to check for cooling and heating operation issues and further troubleshooting. See [Checking cooling and heating operation](#). You must use a pressure gauge tool as part of this procedure. [Figure 37](#) shows the refrigerant system with a pressure gauge attached.

Figure 37: Checking the refrigerant system

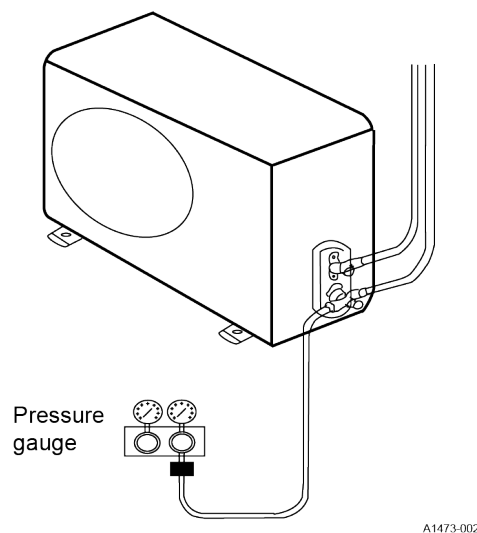

To check refrigerant system components, do the following:

1. Test the refrigerant system flow. Make sure that the following conditions are met:
 - The compressor is running.
 - The outdoor unit is installed in a well-ventilated area.
2. Check the refrigerant system using a pressure gauge tool as needed as follows:
 - See the defrost cycle in operation.
 - Measure the refrigerant piping temperature.
 - Test the refrigerant piping pressure.

Checking cooling and heating operation

- Use the cooling mode flow chart to check for cooling operation issues. See [Figure 38](#).
- Use the heating mode flow chart to check for heating operation issues. See [Figure 39](#).

Figure 38: Cooling mode flow chart

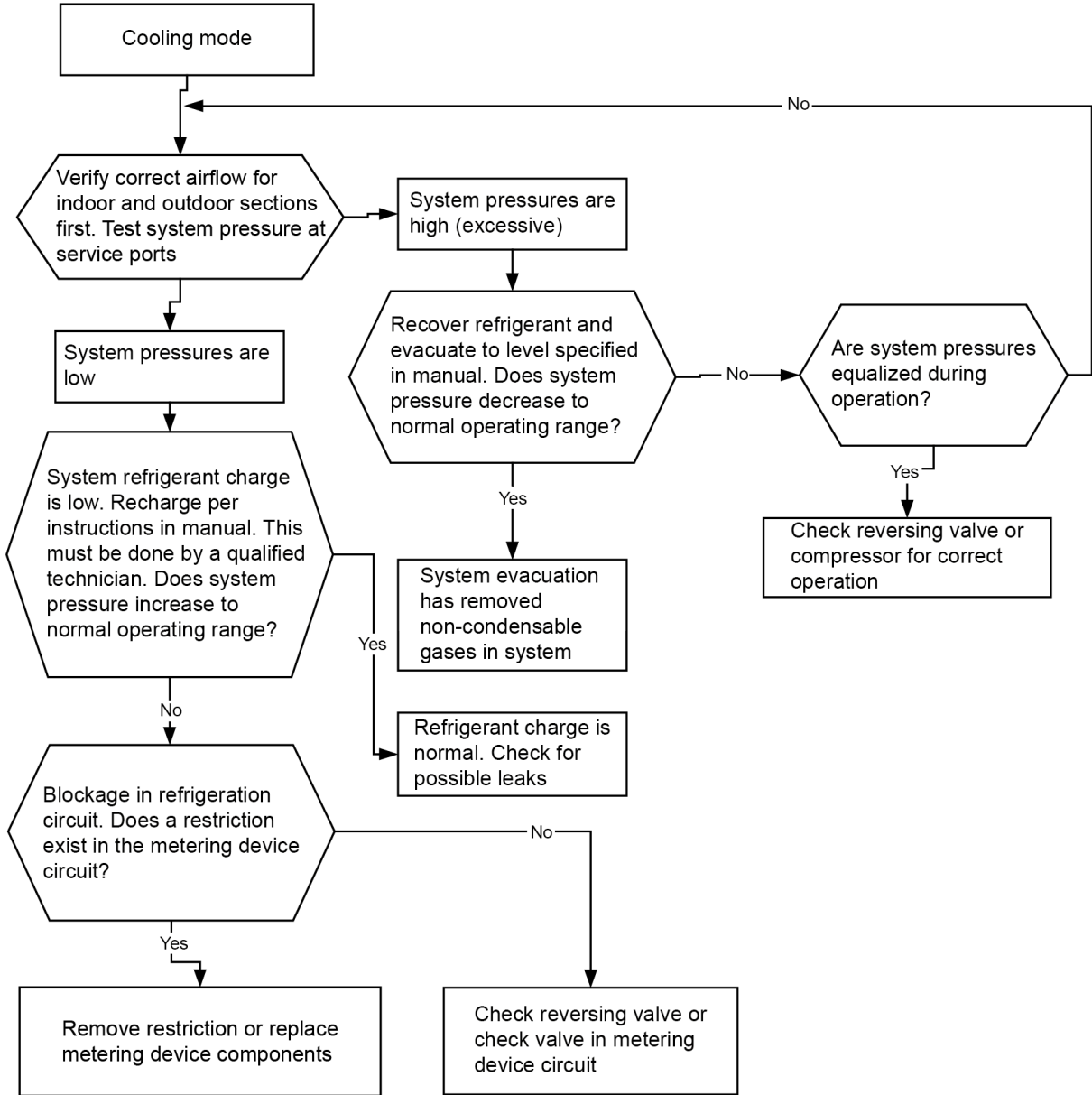

A1474-002

Figure 39: Heating mode flow chart

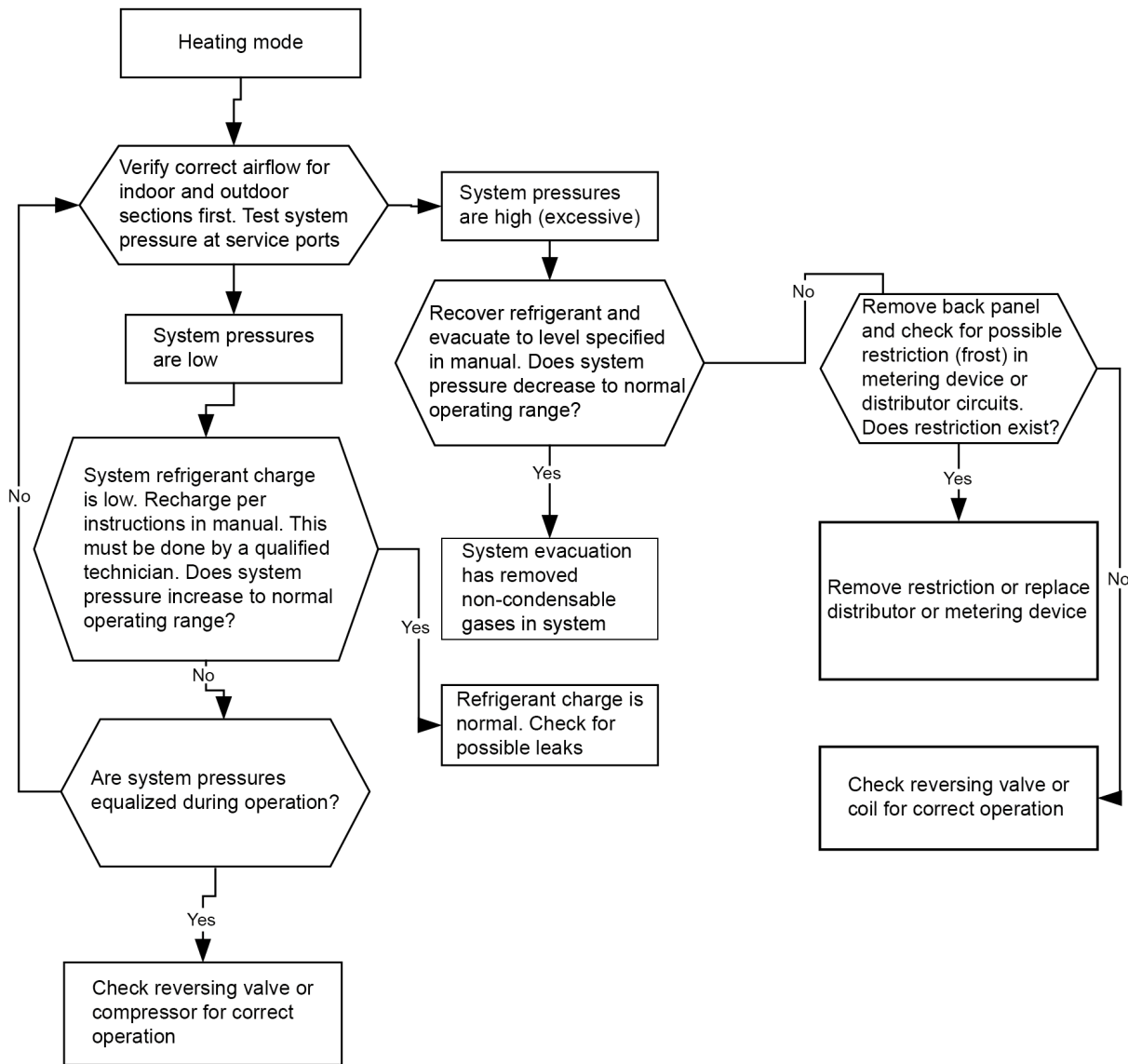

A1475-002

Viewing fault codes and protection codes for all VH4 outdoor models

For VH4 outdoor units, the 7-segment display on the 7-segment display control board indicates outdoor unit fault codes and protection codes, and LED1, LED2, and LED3 on the main control board indicate drive fault codes.

The 7-segment display on the 7-segment display control board displays active outdoor unit fault codes and protection codes when you run a parameter query for the P.0 parameter code. See [Checking outdoor unit parameters](#) and [Running a parameter query for all VH4 outdoor models](#) for more information. Figure 40 illustrates how outdoor unit fault codes or protection codes display when you select the P.0 parameter code. If there are multiple outdoor unit fault codes or protection codes, the codes display in sequence. See [Outdoor unit faults and protection](#) for troubleshooting guidance for specific outdoor unit fault codes and protection codes.

Figure 40: Outdoor unit fault code or protection code display

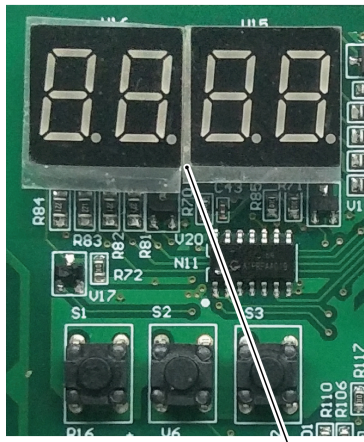

E displays with outdoor unit fault code or protection code, for example, E 13

LED1, LED2, and LED3 on the main control board (**DC - inverter unitary**) indicate active drive fault codes and if the compressor is preheating. Figure 41 shows the location of the LEDs. To view the LEDs, remove the system top cover.

Figure 41: LEDs for VH4

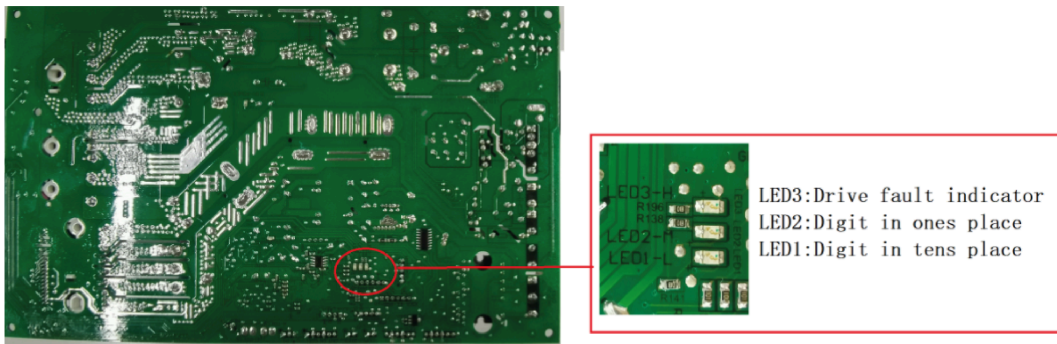

A2036-001

① **Note:** The design of the main control board is upside down as shown in [Figure 41](#).

As shown in [Figure 41](#), LED1 indicates digits in drive fault code numbers that are in the tens place and LED2 indicates digits in drive fault code numbers that are in the ones place. If a fault code contain two digits, LED1 indicates the first digit and LED2 indicates the second digit. For example, if the fault code is 23, LED1 flashes on and off two times and LED 2 flashes on and off three times. If a fault code contains a single digit, LED2 indicates the digit. For example, if the fault code is 5, LED2 flashes on and off five times. LED3 indicates that a drive fault is present.

It is important to check the status of all three LEDs to understand what the LEDs are indicating:

- When LED3 is on, LED1 and LED2 indicate active drive fault codes.
- When LED3 is flashing, and LED1 and LED2 are off, this indicates that the compressor is preheating.
- When LED1, LED2, and LED3 are off, this indicates that there are no drive faults and the compressor is not preheating.

Drive fault codes display in sequence at intervals of 5 s. This means that an LED is off for 5 s to report the next fault code. See [Figure 42](#) for an example of drive fault code display and timing. See [Drive faults](#) for troubleshooting guidance for specific drive fault codes.

Figure 42: Example of drive fault code 32

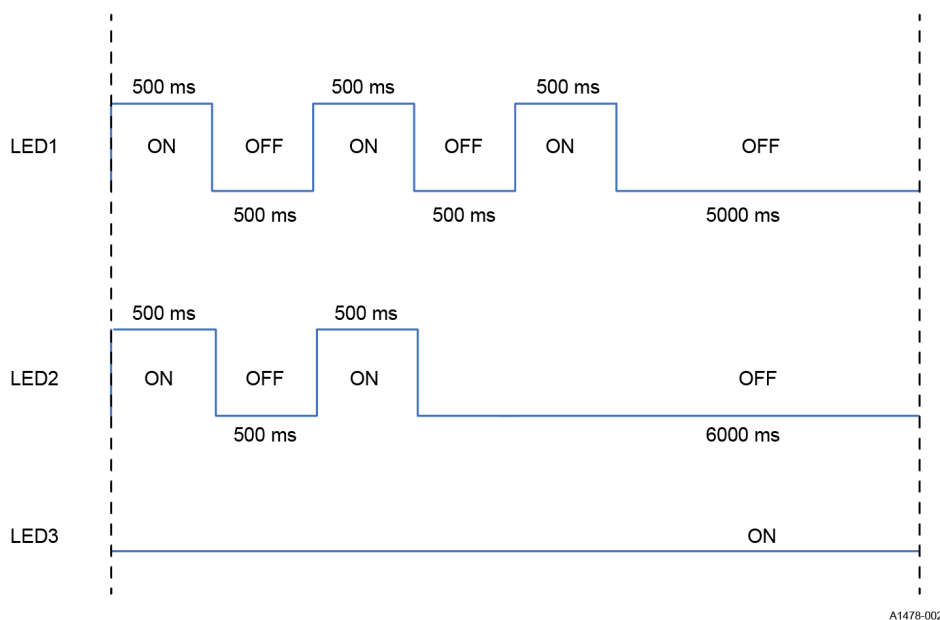

Normal malfunction

Table 33: Troubleshooting for normal malfunction

Condition	Cause	Solution
The outdoor unit does not start.	Power supply failure.	Check the power supply circuit.
	Trip of breaker or open fuse.	Measure the insulation resistance to ground to see if there is any leakage.
	Supplied voltage is too low.	Check if there is a defective contact or leakage current in the power supply circuit.
	Incorrect setting of the thermostat.	Check and set the thermostat.
	No power to the thermostat.	Check the thermostat and thermostat wiring.
The compressor starts or stops frequently.	The air inlet or air outlet is blocked or restricted.	Remove the blockage.
Poor cooling or heating.	The outdoor heat exchanger is dirty.	Clean the heat exchanger of the outdoor unit.
	Air leakage into the conditioned space or excessive load due to occupants entering and exiting frequently.	Improve the air tightness in the conditioned space.
	Blockage of outdoor heat exchanger.	Remove the blockage.
	Incorrect temperature setting.	Check the thermostat and try to set the temperature again.
Sound from deforming parts.	During system starting or stopping, a sound might be heard. This is due to thermal deformation of plastic parts.	Note that this is normal and the sound disappears quickly.
There is water leakage.	The drainage pipe is blocked or broken.	Change the drainage pipe.
	The insulation of the refrigerant piping is inadequate.	Correct the refrigeration piping insulation.
Indoor unit running at high stage airflow and the outdoor unit does not start.	Defective A2L sensor or refrigerant leakage in the system.	Identify if there is a defect in the A2L sensor or a refrigerant leakage in the system and fix it.

Outdoor unit faults and protection

Table 34: Troubleshooting for outdoor unit fault codes and protection codes

Fault or protection code	Condition	Cause	Solution	Comment
1	Outdoor ambient temperature sensor fault.	The outdoor ambient temperature sensor has a poor connection.	Reconnect the outdoor ambient temperature sensor.	—
		Outdoor ambient temperature sensor failure.	Replace the outdoor ambient temperature sensor components.	
		Sampling circuit failure.	Replace the outdoor control board components.	
2	Outdoor coil temperature sensor fault.	The outdoor coil temperature sensor has a poor connection.	Reconnect the outdoor coil temperature sensor.	—
		Outdoor coil temperature sensor failure.	Replace the outdoor coil temperature sensor components.	
		Sampling circuit failure.	Replace the outdoor control board components.	
3	Unit overcurrent turn-off fault.	Control board current sampling circuit failure.	Replace the electrical control board components.	—
		The current is excessive because the supply voltage is too low.	Outdoor unit protection activates.	
		The compressor is blocked.	Replace the compressor.	
		Overload in cooling mode.	See Overload in cooling mode .	
		Overload in heating mode.	See Overload in heating mode .	
4	EEprom data error.	EE components failure.	Replace the EE components.	—
		EE components control circuit failure.	Replace the outdoor control board components.	
		The EE components are inserted incorrectly.	Reassemble the EE components.	

Table 34: Troubleshooting for outdoor unit fault codes and protection codes

Fault or protection code	Condition	Cause	Solution	Comment
5	Cooling freezing protection because the indoor coil temperature is too low or heating overload because the indoor coil temperature is too high.	Indoor unit airflow restriction.	Check if the indoor fan, indoor fan motor, and indoor coil function normally.	—
		The room temperature is too low in cooling mode or the room temperature is too high in heating mode.	Outdoor unit protection activates.	
		The filter is dirty.	Clean the filter.	
		The duct resistance is too high resulting in low airflow.	Correct the duct system.	
		The selected indoor fan speed is too low.	Select a higher indoor fan speed.	
		The indoor unit is not installed in accordance with the installation instructions, and the air inlet is too close to the air outlet.	Reinstall the indoor unit referring to the installation instructions to resolve issues.	
7	Communication (24 V low voltage connection)	The low-voltage cable is connected incorrectly between the indoor and outdoor units.	Reconnect the low-voltage cable. Refer to the wiring diagram.	—
		The low-voltage cable is connected loosely.	Reconnect the low-voltage cable.	
		The low-voltage cable has failed.	Replace the low-voltage cable.	
		Outdoor control board failure.	Replace the outdoor control board.	
		The low-voltage circuit fuse is open.	Check the low-voltage circuit, and adjust the DIP switch and the short-circuit fuse.	
		The low-voltage cable is incorrect.	Choose suitable low-voltage cable. Refer to the installation instructions.	

Table 34: Troubleshooting for outdoor unit fault codes and protection codes

Fault or protection code	Condition	Cause	Solution	Comment
13	Compressor overheat protector device.	The overload protector wiring has a poor connection.	Reconnect the overload protector wiring.	—
		Overload protector failure.	Replace the overload protector.	
		Low refrigerant charge.	Check the brazed joints for refrigerant leaks and adjust the refrigerant charge.	
		Long refrigerant piping length applied without additional charge.	Adjust the refrigerant charge.	
		EEV failure.	Replace the EEV.	
		Outdoor control board failure.	Replace the outdoor control board.	
14	The high-pressure switch has opened or the outdoor unit has shut down for high-pressure switch protection.	The high-pressure switch wiring has a poor connection.	Reconnect the high-pressure switch wiring.	Applies to models with high-pressure switch or pressure sensor.
		High-pressure switch failure.	Replace the high-pressure switch.	
		The outdoor control board is abnormal.	Replace the outdoor control board.	
		Overload in cooling.	See Overload in cooling mode .	
		Overload in heating.	See Overload in heating mode .	
15	The low-pressure switch has opened or the outdoor unit has shut down for low-pressure protection.	The low-pressure switch wiring has a poor connection.	Reconnect the low-pressure switch wiring.	Applies to models with low-pressure switch or pressure sensor.
		Low-pressure switch failure.	Replace the low-pressure switch.	
		Low refrigerant charge.	Check the brazed joints for refrigerant leaks and adjust the refrigerant charge.	
		EEV failure in heating mode.	Replace the EEV.	
		The outdoor control board is abnormal.	Replace the outdoor control board.	
16	Overload protection in cooling mode.	System overload.	See Overload in cooling mode .	—

Table 34: Troubleshooting for outdoor unit fault codes and protection codes

Fault or protection code	Condition	Cause	Solution	Comment
17	Discharge temperature sensor fault.	The discharge temperature sensor wiring has a poor connection.	Reconnect the discharge temperature sensor wiring.	—
		Discharge temperature sensor failure.	Replace the discharge temperature sensor.	
		The sampling circuit is abnormal.	Replace the outdoor control board.	
18	AC voltage is abnormal.	The AC voltage is >275 V or <160 V.	Outdoor unit protection activates. Check the supply power.	—
		The AC voltage of the sampling circuit on the drive board is abnormal.	Replace the drive board.	
19	Suction temperature sensor fault.	The suction temperature sensor wiring has a poor connection.	Reconnect the suction temperature sensor wiring.	—
		Suction temperature sensor failure.	Replace the suction temperature sensor.	
		The sampling circuit is abnormal.	Replace the outdoor control board.	
22	Defrost sensor fault.	The defrost sensor wiring has a poor connection.	Reconnect the defrost sensor wiring.	—
		Defrost sensor failure.	Replace the defrost sensor.	
		The sampling circuit is abnormal.	Replace the outdoor control board.	
43	High-pressure sensor fault.	The high-pressure sensor wiring has a poor connection.	Reconnect the high-pressure sensor wiring.	—
		High-pressure sensor failure.	Replace the high-pressure sensor.	
		High-pressure sensor sampling circuit failure.	Replace the outdoor control board.	
45	IPM fault.	Drive or amplifier fault.	See Table 35 and for troubleshooting guidance for drive fault codes.	—

Table 34: Troubleshooting for outdoor unit fault codes and protection codes

Fault or protection code	Condition	Cause	Solution	Comment
46	IPM and control board communication fault.	The communication cable between the control board and the drive board has a poor connection.	Reconnect the communication cable between the control board and the drive board.	—
		The communication cable between the control board and the drive board has failed.	Replace the communication cable between the control board and the drive board.	
		Drive board failure.	Replace the drive board.	
		Control board failure.	Replace the control board.	
47	Excessive discharge temperature fault.	Low refrigerant charge.	Check the brazed joints for refrigerant leaks and adjust the refrigerant charge.	—
		Low charge due to extended refrigerant piping.	Adjust the refrigerant charge.	
		Metering system failure.	Replace the metering devices.	
		Excessive outdoor ambient temperature.	Outdoor unit protection activates.	
48	Outdoor DC fan motor fault - upper fan motor.	The DC fan motor wiring has a poor connection.	Reconnect the DC fan motor wiring.	—
		The wiring to the DC fan motor has failed.	Replace the DC fan motor.	
		DC fan motor failure.	Replace the DC fan motor.	
		DC fan motor drive circuit failure.	Replace the drive board of the DC fan motor.	
		Outdoor unit airflow blockage.	Resolve the outdoor unit airflow restriction.	
49	Outdoor DC fan motor fault - lower fan motor.	The DC fan motor wiring has a poor connection.	Reconnect the DC fan motor wiring.	—
		The wiring to the DC fan motor has failed.	Replace the DC fan motor.	
		DC fan motor failure.	Replace the DC fan motor.	
		DC fan motor drive circuit failure.	Replace the drive board of the DC fan motor.	
		Outdoor unit airflow blockage.	Resolve the outdoor unit airflow restriction.	

Table 34: Troubleshooting for outdoor unit fault codes and protection codes

Fault or protection code	Condition	Cause	Solution	Comment
91	Outdoor unit stops due to IPM board overheating fault.	The outdoor ambient temperature is too high.	Outdoor unit protection activates.	—
		The speed of the outdoor fan motor is too low.	Check the outdoor fan motor and replace if necessary.	
		The outdoor unit is not installed in accordance with the installation instructions.	Reinstall the outdoor unit in accordance with the installation instructions.	
		The supply power is too low.	Outdoor unit protection activates.	
96	Low charge.	Inadequate system charge.	Recover the refrigerant and adjust the refrigerant charge. Refer to the nameplate and the <i>Tabular Data Sheet</i> .	—
97	Four-way valve failure.	The four-way valve coil wiring has a poor connection.	Reconnect the wiring of the four-way valve.	—
		Four-way valve coil failure.	Replace the four-way valve coil.	
		Four-way valve failure.	Replace the four-way valve.	
		Four-way valve drive board failure.	Replace the drive board of the four-way valve.	

Drive faults

Table 35: Troubleshooting for drive fault codes for all VH4 outdoor models

Fault code	Condition	Cause	Solution
1	Inverter DC voltage overload fault.	The power supply input is too high or too low.	Check the power supply.
2	Inverter DC low-voltage fault.		
3	Inverter AC current overload fault.	Drive board fault.	Change the drive board.
4	Out-of-step detection.	Compressor phase lost.	Check the compressor wiring and connections.
5	Loss phase detection fault - speed pulsation.		
6	Loss phase detection fault - current imbalance.	Bad drive board components.	Change the drive board.
		Compressor insulation fault.	Change the compressor.
7	Inverter IPM fault - edge.	System overload or current overload.	Check the system.
8	Inverter IPM fault - level.		
9	PFC_IPM IPM fault - edge.	Drive board fault.	Change the drive board.
10	PFC_IPM IPM fault - level.	Compressor oil shortage. Serious wear of crankshaft.	Change the compressor.
		Compressor insulation fault.	Change the compressor.
12	PFC overload current detection of failure.	System overload. The current is too high.	Check the system.
		Drive board failure.	Change the drive board.
		PFC failure.	Change the PFC.
13	DC voltage detected abnormal.	The input voltage is too high or too low.	Check the power supply.
14	PFC low voltage detected failure.		
		Drive board failure.	Change the drive board.
15	AD offset abnormal detected failure.	Drive board failure.	Change the drive board.
17	Inverter PWM initialization failure.		
19	PFC_PWM initialization fault.		
20	Temperature is abnormal.		
21	Shunt resistance unbalance adjustment fault.		
22	Communication failure.	The communication wire is not connected correctly.	Check the wiring.
		Drive board failure.	Change the drive board.
		Control board failure.	Change the control board.
23	Incorrect motor parameters.	Initialization is abnormal.	Reset the power supply.
26	DC voltage mutation error.	The power input changes suddenly.	Check that the power supply is stable.
		Drive board failure.	Change the drive board.

Table 35: Troubleshooting for drive fault codes for all VH4 outdoor models

Fault code	Condition	Cause	Solution
27	D axis current control error.	System overload. The phase current is too high.	Check the system to see if it works normally. Check the stop valve to see if it is open.
		Drive board failure.	Change the drive board.
28	Q axis current control error.	System overload. The phase current is too high.	Check the system to see if it works normally. Check the stop valve to see if it is open.
		Drive board failure.	Change the drive board.
29	Saturation error of D axis current control integral.	Momentary system overload.	Check the system to see if it works normally.
		The compressor parameter is not suitable.	Check the stop valve to see if it is open.
		Drive board failure.	Change the drive board.
30	Saturation error of Q axis current control integral.	Momentary system overload.	Check the system to see if it works normally.
		The compressor parameter is not suitable.	Check the stop valve to make sure that the stop valve is open.
		Drive board failure.	Change the drive board.

Overload in cooling mode

Table 36: Troubleshooting for overload in cooling mode

Condition	Cause	Solution
Overload in cooling mode	The refrigerant is excessive.	Recover the refrigerant, and adjust the refrigerant charge. Refer to the nameplate and the <i>Tabular Data Sheet</i> .
	The outdoor ambient temperature is too high.	Use the outdoor unit within the allowable temperature range.
	There is a short-circuit in the air outlet and air inlet of the outdoor unit.	Adjust the installation of the outdoor unit referring to the installation instructions.
	The outdoor heat exchanger is dirty.	Clean the heat exchanger of the outdoor unit.
	The speed of the outdoor fan motor is too low.	Check the outdoor fan motor operation and replace the outdoor fan motor if necessary.
	The outdoor fan is damaged or blocked.	Check the outdoor fan.
	The air inlet and air outlet are blocked.	Remove the obstructions.
	The TXV has failed.	Replace the TXV.

Overload in heating mode

Table 37: Troubleshooting for overload in heating mode

Condition	Cause	Solution
Overload in heating mode	The refrigerant is excessive.	Recover the refrigerant, and adjust the refrigerant charge. Refer to the nameplate and the <i>Tabular Data Sheet</i> .
	The indoor ambient temperature is too high.	Use the outdoor unit within the allowable temperature range.
	There is a short-circuit in the air outlet and air inlet of the indoor unit.	Adjust the installation of the indoor unit referring to the installation instructions.
	The indoor filter is dirty.	Clean the indoor filter.
	The speed of the indoor fan motor is too low.	Check the indoor fan motor operation and replace the indoor fan motor if necessary.
	The indoor fan is not operating correctly.	Check the indoor fan.
	The air inlet and air outlet are blocked.	Remove the obstructions.
	The EEV has failed.	Replace the EEV.

Third-party trademarks notice

Third-Party Trademarks Notice: For information about third-party trademarks, refer to the relevant company websites.

① **Note:** See Figure 26 for DIP switch settings.

Figure 44: Electrical wiring diagram for VH442E2S11, VH448E2S11, and VH460E2S11

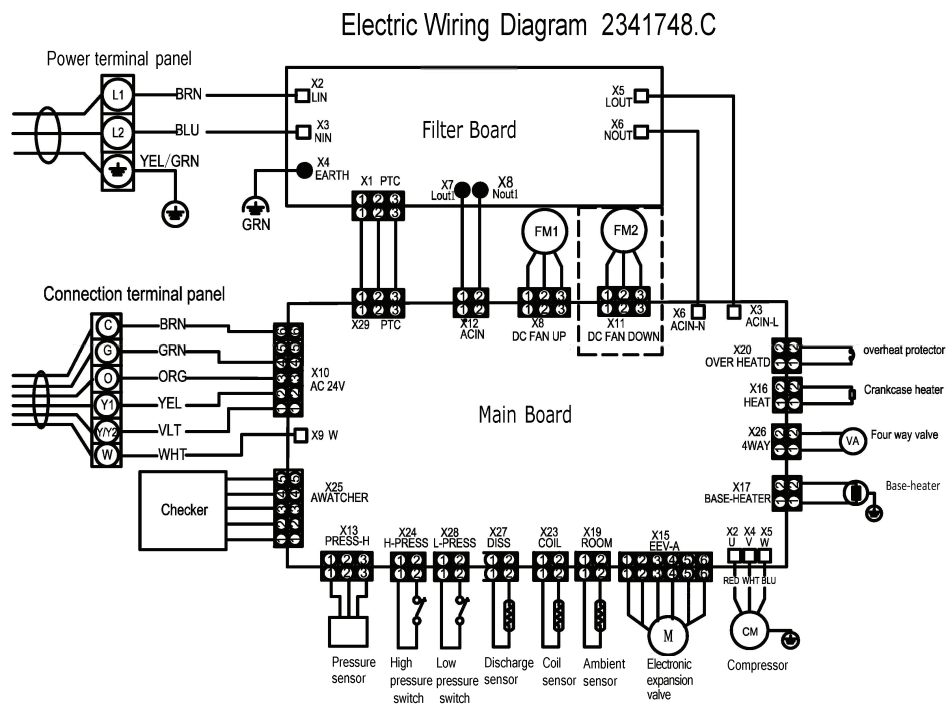

6812175-UWD-A-0225

Start-up sheet

Residential split variable capacity system unit with electric heat start-up sheet

Correct start-up is critical to customer comfort and equipment longevity

Start-up date	Company name	Start-up technician
Dealer training certification number		

Owner information

Name	Address	Daytime phone
City	State or province	Zip or postal code

Equipment data

Outdoor unit model	Unit serial number
Indoor coil or air handler model	Unit serial number
Furnace model	Unit serial number
Thermostat model	Unit serial number

General information (Check all that apply)

<input type="radio"/> New construction	<input type="radio"/> Roof level	<input type="radio"/> Downflow	<input type="radio"/> Horizontal
<input type="radio"/> Retrofit	<input type="radio"/> Grade level	<input type="radio"/> Upflow	

Unit location and connections (Check all that apply)

<input type="checkbox"/> Unit is level and installed on:	<input type="checkbox"/> Slab	<input type="checkbox"/> Roof curb	<input type="checkbox"/> Duct connections are complete:	<input type="checkbox"/> Supply	<input type="checkbox"/> Return
<input type="checkbox"/> Condensate drain correctly connected per the installation instructions		<input type="checkbox"/> Condensate trap primed with water			

Filters

<input type="checkbox"/> Filters installed	Number of filters	Filter size
--	-------------------	-------------

Electrical connections and inspection (Check all that apply)

<input type="radio"/> 208 VAC	<input type="radio"/> 230 VAC	
<input type="checkbox"/> Inspect wires and electrical connections	<input type="checkbox"/> Transformer wired correctly for primary supply voltage	<input type="checkbox"/> Ground connected
<input type="checkbox"/> Low voltage present at control board R and C	Measured voltage R and C outdoor unit control board	
<input type="checkbox"/> Line voltage present at disconnect	Measured voltage L1 to L2	
Total amperes L1	L2	

Airflow setup or cooling Motor terminal

Blower type and set-up	<input type="radio"/> ECM	Compressor high	<input type="radio"/> 1	<input type="radio"/> 2	<input type="radio"/> 3	<input type="radio"/> 4	<input type="radio"/> 5
		Compressor low	<input type="radio"/> 1	<input type="radio"/> 2	<input type="radio"/> 3	<input type="radio"/> 4	<input type="radio"/> 5
		Continuous fan	<input type="radio"/> 1	<input type="radio"/> 2	<input type="radio"/> 3	<input type="radio"/> 4	<input type="radio"/> 5
		Electric heat	<input type="radio"/> 1	<input type="radio"/> 2	<input type="radio"/> 3	<input type="radio"/> 4	<input type="radio"/> 5
Supply static (in. W.C.)		Supply air dry bulb temperature		Supply air wet bulb temperature			
Return static (in. W.C.)		Return air dry bulb temperature		Return air wet bulb temperature			
Total external static pressure		Temperature drop		Outside air dry bulb temperature			

Refrigerant charge and metering device

<input type="checkbox"/> R-454B	Suction line temperature <input type="text"/>	Discharge pressure <input type="text"/>
Data plate - lb-oz <input type="text"/>	Suction pressure <input type="text"/>	Liquid line temperature <input type="text"/>
Discharge line temperature <input type="text"/>	Superheat <input type="text"/>	Subcooling <input type="text"/>

Electric heat

Electric heat kit model <input type="text"/>	Serial number <input type="text"/>	Rated kW <input type="text"/>
Single phase or three phase	Measured amperage	Heater 1 <input type="text"/> Heater 2 <input type="text"/> Heater 3 <input type="text"/> Heater 4 <input type="text"/> Heater 5 <input type="text"/> Heater 6 <input type="text"/>
	Measured voltage	Heater 1 <input type="text"/> Heater 2 <input type="text"/> Heater 3 <input type="text"/> Heater 4 <input type="text"/> Heater 5 <input type="text"/> Heater 6 <input type="text"/>
Number of elements <input type="text"/>	Heating return air dry bulb temperature <input type="text"/>	Heating supply air dry bulb temperature <input type="text"/> Air temperature rise <input type="text"/>

Clean up job site

Job site has been cleaned and indoor and outdoor debris removed from job site

Tools have been removed from unit

All panels have been installed

Unit operation and cycle test

Operate the unit through continuous fan cycles from the thermostat, noting and correcting any problems

Operate the unit through cooling cycles from the thermostat, noting and correcting any problems

Owner education

Provide owner with the user's information manual

Explain operation of system to equipment owner

Explain thermostat use and programming (if applicable) to owner

Explain the importance of regular filter replacement and equipment maintenance

Explain the importance of registering the unit for warranty

Comments and additional job details